

**Hydrophilic Antioxidant Activity, Vitamin C and Total
Phenol Content of Selected Varieties of Commonly
Consumed Fruits and Vegetables of Bangladesh**

Submitted By

Nuhad Raisa Seoty

M.Phil. Session: 2009-2010

Registration No.: 245/2009-2010



Institute of Nutrition and Food Science

University of Dhaka

Dedicated to My Daughter

Nashwa Nawal Khan

ACKNOWLEDGEMENT

I would like to take this opportunity to thank all the persons who have contributed in the different aspects of the study. They have all made it possible for me to commence and complete this enormous task. I would like to acknowledge and commend them for their effort, cooperation and that have worked towards the success of this study. I would like to acknowledge the contribution of my family, friends, evaluators with whom I have worked during this study.

I am deeply grateful to my supervisor Dr. Nazma Shaheen, Professor, Institute of Nutrition and Food Science, University of Dhaka, for patiently taking me through this difficult task of research and also for the extra hours that she invested in introducing me to the field of scientific research.

I would like to thank my co-supervisor Md. Mohiduzzaman, Professor, Institute of Nutrition and Food Science, University of Dhaka, for his generous supports and encouragement to complete the course.

I would like to thank Cadi Parvin Banu, Principal Research Associate, Institute of Nutrition and Food Science, University of Dhaka for her patience and support that helped me to overcome many crisis situations and finish this study.

I wish to express my special gratitude to Dr. Najim Uddin, Senior Scientific officer, Bangladesh Agricultural Research Institute, Gazipur.

I would like to thank to my honorable teachers of Institute of Nutrition and Food Science, University of Dhaka for their positive and inspiring attitude towards me.

I would like to thank Director of Center for Advanced Research in Sciences (CARS) University of Dhaka for giving me permission to use the laboratory and necessary instruments whenever I need.

I am grateful to Avonti Basak Tukun, for her kind support from the beginning of my research work. Special thanks to Saiful Islam, Kazi Turjaun Akhter, Rakhi Nandi, Keya Apa, Madhabi Apa for their heartiest co-operation.

Finally, I appreciate the financial support from Ministry of Science and Technology, Government of the People's Republic of Bangladesh that funded parts of the research discussed in this thesis.

ABSTRACT

Fruits and vegetables contain a wide variety of phytochemicals including thousands of bioactive compounds, many of which are implicated with health effects like protective action against heart disease, hypertension, diabetes and some form of cancer. The present study involved to estimate the content of vitamin C and total phenol and assessing the antioxidant activity in the hydrophilic extracts from edible portions of five different fruits and five vegetables commonly consumed by Bangladeshi people. The fruits analyzed included a total of 11 varieties from Banana, Guava, Lemon, Mango and Pineapple, and the vegetables covering a total of 17 varieties included Bottle Gourd, Brinjal, Pumpkin, Radish and Tomato – all the varieties of a particular fruit or vegetable followed a standard cultivation system in the research field of Bangladesh Agricultural Research Institute (BARI). After collection, samples were prepared by washing (under running tap water followed by distilled water), air-drying, dressing and weighting of refusal. A portion of the edible parts of fresh sample was used for the analysis of Vitamin C content employing the principles and techniques of High-Performance Liquid Chromatography (HPLC). The remaining portion was freeze-dried at -180°C , weighed, ground and stored in air tight package at -20°C until sequential extraction by Hexane: Dichloromethane (1:1) followed by acetone: water: acetic acid (70:29.5:0.5) to get the hydrophilic extracts for the estimation of Total Phenol Content (TPC) and Antioxidant Activity (AA) according to the Folin-Ciocalteu method and 2, 2-diphenyl-1-picrylhydrazyl radical scavenging assay (DPPH-RSA) respectively. Vitamin C content (mean \pm SD), expressed as mg L-Ascorbic Acid (L-AA)/100 g fresh weight (FW), of different varieties of fruits and vegetables respectively varied from 1.03 ± 0.15 in Banana (BARI Kola-2) to 71.57 ± 2.83 in Guava (BARI Peara-2) and 0.33 ± 0.05 in Brinjal (BARI Hybrid Begun-3) to 14.43 ± 0.21 in Radish (BARI Mula-2: Pinky). For vegetables, TPC (mean \pm SD), expressed as μg Galic Acid Equivalent (GAE)/100g FW, ranged from $0.07\times 10^4\pm 0.00$ in Radish (BARI Mula-3: Druti) to $3.23\times 10^4\pm 0.24$ in Brinjal (BARI Begun-1: Uttara). For fruits, TPC varied from $0.14\times 10^4\pm 0.01$ in Pineapple (Justice) to $11.31\times 10^4\pm 0.11$ in Guava (BARI Kazi Peara). Among the fruits, the highest AA (mean \pm SD), 428.40 ± 4.50

μM Trolox Equivalent (TE)/100g FW was observed in Guava (BARI Peara-2) and the lowest in Lemon (BARI Lebu-3) at a level of $6.41 \pm 0.0 \mu\text{M TE}/100\text{g FW}$. In vegetables, AA (mean \pm SD) ranged from $3.00 \pm 1.20 \mu\text{M TE}/100\text{g FW}$ in Bottle Gourd (BARI Lau-3) to $107.00 \pm 24.78 \mu\text{M TE}/100\text{g FW}$ in Brinjal (BARI Begun-8). In two varieties of Guava (BARI Kazi Peara and BARI Peara-2), AA, TPC and Vitamin C were high of all the values. The Vitamin C content of Lemon (BARI Lebu-3) was high although its AA was negligible with TPC being below the detection level. BARI Aam-3, a variety of Mango demonstrated high AA and Vitamin C while TPC was low. TPC was high in two varieties of Banana (BARI Kola-1: BARI Sagar Kola, BARI Kola-2). Three varieties of Brinjal as BARI Begun-1: Uttara, BARI Begun-4: Kajla and BARI Begun-8 showed AA and TPC, and two varieties of Radish like BARI Mula-2: Druti and BARI Mula-3: Pinky demonstrated Vitamin C in highest position among all studied vegetables. The findings of the present study indicates that some of the selected varieties of fruits and vegetables cultivated by BARI contain considerable amount of Vitamin C and Phenolic compounds that may serve as a potential source of dietary antioxidants in order to help the balance of body's antioxidant defense system against oxidative stress.

ABBREVIATION

AA	Antioxidant Activity
TPC	Total Phenol Content
L-AA	L-Ascorbic Acid
GAE	Gallic Acid Equivalent
TE	Trolox Equivalent
BARI	Bangladesh Agricultural Research Institute
HPLC	High Performance Liquid Chromatography
DPPH-RSA	2, 2-diphenyl-1-1-picrylhydrazyl radical scavenging assay
ROS	Reactive Oxygen Species
RNS	Reactive Nitrogen Species
RDA	Recommended Dietary Allowances
FNB	Food and Nutrition Board
FW	Fresh Weight
DW	Dry Weight
mg	Miligram
µg	Microgram
g	Gram

TABLE OF CONTENTS

Title	Page No.
ACKNOWLEDGEMENT	I-II
ABSTRACT	III-IV
ABBREVIATION	V
LIST OF CONTENTS	VI-XIV
CHAPTER 1: Introduction	1-6
1.1 Background	1
1.2 Rational of the study	3
1.3 Objective of the study	6
CHAPTER 2: Literature Review	7-51
2.1 Introduction to antioxidant	7-14
2.1.1 Antioxidants and free radicals	7
2.1.2 How antioxidants work	8
2.1.3 Types of antioxidants	9
2.1.3.1 Antioxidant nutrients	9
2.1.3.2 Antioxidant enzymes	11
2.1.4 Health benefits of antioxidants	11
2.1.5 RDA for dietary antioxidants	12
2.1.6 Sources of antioxidants in food	13
2.1.7 High dose antioxidant supplements	14

2.2 Introduction to phenolic compounds	14-39
2.2.1 Phenolic compounds	14
2.2.2 Phenolic compounds and their sources	16
2.2.3 Polyphenols: food sources and bioavailability	18
2.2.4 Protection by dietary polyphenols	20
2.2.5 Classification and structure of phenolic compounds	20
2.2.6 Flavonoids and other compounds	24
2.2.6.1 Quercetin	26
2.2.6.2 Epicatechin	26
2.2.6.3 Tannins	27
2.2.6.4 Chalcone	27
2.2.7 Phenolic acids	28
2.2.8 Avenanthramides	28
2.2.9 Lignans	28
2.2.10 Catechins	29
2.2.11 Gingerol	29
2.2.12 Coumerins	30
2.2.13 Dietary intake of plant polyphenols	30
2.2.14 Bioavailability of polyphenol compounds	31
2.2.15 Intestinal absorption and metabolism	31
2.2.16 Metabolism by the gut micro flora	31
2.2.17 Plasma transport and partitioning into lipid structures	32
2.2.18 Plasma concentrations	33

2.2.19 Tissue uptake	33
2.2.20 Elimination	33
2.2.21 Protection by dietary polyphenols	34
2.2.22 Antioxidant properties of polyphenols	34
2. 2.23 Polyphenols and Human Diseases	35
2. 2.23.1 Cardio-Protective Effect	36
2. 2.23.2 Anti-Cancer Effect	36
2.2.23.3 Anti-Diabetic Effect	37
2.2.23.4 Anti-Aging Effect	38
2.2.23.5 Neuro-Protective Effects	38
2. 2.23.6 Polyphenols and osteoporosis	38
2. 2.24 Risks associated to polyphenol consumption	39
2.3 Introduction to Vitamin C	39-47
2.3.1 Nomenclature and structure	39
2.3.2 Vitamin C is an electron donor and therefore a reducing agent	40
2.3.3 Enzymology of vitamin C	42
2.3.4 Vitamin C as an Antioxidant in Human Biology	42
2.3.5 Detection of Vitamin C Action as an Antioxidant: Biomarkers of Oxidative Reactions	43
2.3.6 Dietary Availability	46
2.3.7 Recommendation for Vitamin C consumption	46
2.4 Recent research works on Antioxidant Activities,	48-51

Vitamin C and Total Phenol Content

CHAPTER 3: Methodology	52-72
3.1. Collection of samples	52
3.2. Sample identification & characterization	52-62
3.3 Sample preparation	63
3.4 Estimation of moisture	63
3.5 Principle of estimation of Vitamin C	63
3.6 Extraction of fresh sample for Vitamin C estimation	64-65
3.6.1 Reagents	64
3.6.2 Preparation of metaphosphoric acid stock solution	64
3.6.3 Preparation of 3 M potassium dihydrogen phosphate	64
3.6.4 Preparation of ascorbic acid standard solution	64
3.6.5 Instruments and glass ware	64
3.6.6 Chromatographic conditions	65
3.7 Procedure	65
3.7.1 Sample preparation	65
3.7.2 Analysis	65
3.8 Calculation, Unit of expression and test report	66
3.9 Extraction of freeze dried sample for TPC and AA estimation	67
3.9.1 Reagents	67
3.9.2 Equipment	67
3.9.3 Solvents for extraction	67
3.9.4 Procedure	67

3.10 Principle of estimation of TPC	68-69
3.10.1 Reagents	68
3.10.2 Preparation of gallic acid standard solution	68
3.10.3 Procedure of Total Phenol estimation	69
3.10.4 Calculation	69
3.11 Estimation of Antioxidant Activity by DPPH (RSA)	70-71
3.11.1 Reagents	70
3.11.2 Procedure	70
3.11.2.1 Trolox dilution for working standard	70
3.11.2.2 Sample preparation	70
3.11.2.3 Blank preparation	71
3.11.3 Calculation	71
3.12 Statistical analysis	72
CHAPTER 4: Results	73-85
4.1 Vitamin C (L-Ascorbic acid) content	73-75
4.2 Total Phenol Content (TPC)	75-78
4.3 Antioxidant Activity by DPPH (RSA)	78-81
4.4 Correlation between Total Phenol Content (TPC) and Antioxidant Activity by DPPH Radical Scavenging Assay (RSA)	81-83
4.5 Visual relationship between Total Phenol Content (TPC) and Antioxidant Activity	84-85

CHAPTER 5: Discussion	86-91
CHAPTER 6: Conclusion	92-93
CHAPTER 7: Limitation	94
CHAPTER 8: References	95-122

LIST OF TABLES

Title of the tables	Page No.
Table 2.1 The new and old RDA of the dietary antioxidants for the adults (19 years and older)	12
Table 2.2: Polyphenols in foods	18-19
Table 2.3: The major classes of phenolic compounds in plants	22
Table 2.4: Food sources of Vitamin C	47
Table 4.1: L-Ascorbic Acid content in selected varieties of commonly consumed fruits of Bangladesh	73
Table 4.2: L-Ascorbic Acid content in selected varieties of commonly consumed vegetables of Bangladesh	74
Table 4.3: Total Phenol Content in selected varieties of commonly consumed fruits of Bangladesh	76
Table 4.4: Total Phenol Content in selected varieties of commonly consumed vegetables of Bangladesh	77
Table 4.5: Antioxidant Activity in selected varieties of commonly consumed fruits of Bangladesh by DPPH Radical scavenging assay	79
Table 4.6: Antioxidant Activity in selected varieties of commonly consumed vegetables of Bangladesh by DPPH Radical scavenging assay	80

LIST OF FIGURES

Title of the figures	Page No.
Figure 2.1 Free radical creation and neutralization	8
Figure 2.2 Action of antioxidant	9
Figure 2.3 Increasing protective effect of antioxidant nutrients and enzymes	10
Figure 2.4 The general breakdown of plant-based phenols	15
Figure 2.5: Classification of phenolic compounds	21
Figure 2.6: Basic structure of Flavonoids (C6-C3-C6)	23
Figure 2.7: Classification and chemical structure of major classes of dietary polyphenols	25
Figure 2.8: Quercetin	26
Figure 2.9: Epicatechin	26
Figure 2.10: Tannins	27
Figure 2.11: Chalcone	27
Figure 2.12: Avenanthramides	28
Figure 2.13 : Catechin	29
Figure 2.14: Gingerol	29
Figure 2.15: Coumerin	30
Figure 2.16: Possible routes for consumed polyphenols in humans	32

Figure 2.17 Pleiotropic health beneficial effects of dietary plant polyphenols	35
Figure 2.18: Proposed mechanistic scheme for the prevention of cancer by dietary polyphenols	37
Figure 2.19: Structures of isomers of ascorbic acid	40
Figure 2.20: Vitamin C, an electron donor and consequently a reducing agent	41
Figure 3.1: Peak area of standard solution	46
Figure 3.2: Standard curve for Total Phenol estimation	69
Figure 3.3: Standard curve for antioxidant activity estimation	71
Figure: 4.1: Correlation between TPC and AA among the selected vegetables	81
Figure 4.2: Correlation between TPC and AA among the selected fruits	82
Figure 4.3: Correlation between TPC and AA between two varieties of Tomato	82
Figure: 4.4 Correlation between TPC and AA between two varieties of Radish	83
Figure 4.5: Relationship between Total Phenol Content (TPC) and Antioxidant Activity of selected varieties of commonly consumed fruits	84
Figure 4.6: Visual relationship between Total Phenol Content (TPC) and Antioxidant Activity of selected varieties of commonly consumed vegetables	85

1.1 Background

An increasing number of evidence indicates the role of reactive oxygen species (ROS) such as peroxy radicals (ROO^\bullet), hydroxyl radical (HO^\bullet), superoxide anion ($\text{O}_2^{\bullet-}$) and singlet oxygen ($^1\text{O}_2$) in the pathophysiology of aging and different degenerative diseases such as cancer, cardiovascular diseases, Alzheimer's disease and Parkinson's disease^{1,2}. Living cells possess a protective system of antioxidants, which prevents the formation and enables inactivation of ROS and reactive nitrogen species (RNS).

Oxygen, an element indispensable for life, can adversely affect the human body under certain circumstances. Oxidation processes are very important to living organisms. Most of the potentially harmful effects of oxygen are due to the formation of reactive oxygen species (ROS). The uncontrolled production of ROS and the unbalanced mechanism of antioxidant protection result in the onset of many diseases and accelerate ageing. ROS are a class of highly reactive molecules formed during aerobic life in living organisms and include superoxide anion radicals ($\text{O}_2^{\bullet-}$), hydroxyl radicals (OH^\bullet), and non free-radical species, such as H_2O_2 and singlet oxygen ($^1\text{O}_2$)³. There is a balance between the generation of ROS and inactivation of ROS by the antioxidant system in organisms. When there is imbalance between ROS and antioxidant defense mechanisms, ROS lead to oxidative modification in cellular membranes or intracellular molecules³⁻⁵.

In recent years there has been a remarkable progress in scientific studies dealing with oxidative stress. Several reasons justify this trend: knowledge about reactive oxygen and nitrogen involved in metabolism; definition of markers for oxidative damage; evidence linking chronic diseases and oxidative stress; identification of flavonoids and other dietary polyphenol antioxidants present in plant foods as bioactive molecules; and epidemiological data supporting the idea that health benefits associated with fruits, vegetables and red wine in the diet are probably linked to the polyphenol antioxidants they contain.

Most recent research findings and advanced knowledge in food biochemistry and molecular biology strongly supports the hypothesis that food can modulate various functions in the body in addition to supply the basic nutrients. Considerable interest has been focused on dietary antioxidants with reference to their protective effect against oxidative damage^{6,7}.

The majority of antioxidants taken with the diet are of plant origin. The richest sources of antioxidants are fruits, vegetables, herbs, and grains. The compounds that are the most significant for the antioxidant properties of these raw materials are polyphenols, vitamins A, C, and E, carotenoids etc⁸. Vitamin C an electron donor and therefore a reducing agent is called an antioxidant because, by donating its electrons, it prevents other compounds from being oxidized. However, by the very nature of this reaction, vitamin C itself is oxidized in the process. Again, there are hundreds of polyphenols with antioxidant activity that are potential contributors to the antioxidant mechanisms in humans and animals in general. These compounds are excellent candidates to explain the health benefits of diets rich in fruits and vegetables, although there is still not enough information on food composition data, bioavailability, interaction with other food components and biological effects⁹.

Epidemiological studies have shown that diet rich in vegetables and fruits significantly reduce the incidence of chronic diseases such as cancer and cardiovascular disease^{10,11} and increasing their consumption is a practical approach for chronic diseases prevention¹². Studies have confirmed the health benefits of consumption of high fruits and vegetables, low intake of fruits and vegetables is estimated to cause about 19% of gastrointestinal cancer, 31% of ischemic heart disease and 11% of stroke¹³. The World Health Organization and Food and Agricultural Organization (2003) recommended the daily consumption of at least 400 g of fruit and vegetables for the prevention of heart disease, cancer, type 2 diabetes and obesity¹⁴. The protective effects of vegetables and fruit may be contributed by their antioxidant content^{15,16}. These antioxidants may help to relieve oxidative stress, i.e. preventing free radicals from damaging biomolecules such as

proteins, DNA, and lipids¹⁷. Through additive and synergistic effects, the complex mixture of phytochemicals in vegetables and fruit may provide better protection than a single phytochemical¹², one of the reasons why diet rich in fruits and vegetables from different colour groups is recommended¹⁸.

Establishing data on the antioxidant content of a wide range of vegetables and fruit would be useful for epidemiological research and providing support for dietary guidelines. To encourage fruit consumption among the population it is important to recognize which fruits have the highest antioxidant activity and to promote their regular consumption. Therefore, the main objective of the current work was to estimate the hydrophilic antioxidant capacity, vitamin C and total phenol content of selected varieties of commonly consumed fruits and vegetables of Bangladesh.

1.2 Rationale of the study

Significant number of epidemiological studies have indicated that the oxidative stress imposed by Reactive Oxygen Species (ROS) plays an important role in many chronic and degenerative diseases, such as cardiovascular diseases, cancer, diabetes mellitus, neurodegenerative diseases and ageing^{1,2,19,20}. The scavenging of ROS is thought to be an effective measure to depress the level of oxidative stress in organisms for prevention and treatment of some chronic and degenerative diseases²¹.

Food can modulate various functions of the body, helps to scavenge free radicals owing to the presence of antioxidant nutrients e.g. provitamins, vitamins, minerals as well as non-nutrient bioactive compounds e.g. polyphenols. In recent times, polyphenol compounds present in foods, drew the attention of researchers as a strong antioxidant, as they help to neutralize the free radicals in human body and thus delay the ageing process and also the oxidative damage of tissues, cells, DNA.

Fruits and vegetables are good sources of natural antioxidants, vitamins and minerals, which can play roles to maintain the optimum level of free radical by scavenging ROS in the body. Various studies have demonstrated that intakes of fruits and vegetables rich in

antioxidants are inversely associated with the risk of many chronic diseases, such as cardiovascular diseases and cancer²²⁻²⁹. Flavonoids, a large family of compounds with a C₆-C₃-C₆ skeleton structure, are the most abundant polyphenols in human diets. Polyphenols are regarded as basic to human health and have broad pharmacological effects on human health, especially in prevention of age-related diseases³⁰. Besides phenolic and flavonoid compounds, ascorbic acid (vitamin C) is usually considered to be one of the main reducing substances in fruits and vegetables. Following cereal foods, fruits and vegetables played the second most important role in the traditional Bangladeshi diet.

Due to life styles changes in Bangladesh, some chronic and degenerative diseases, such as cardiovascular diseases, cancer, diabetes mellitus, neurodegenerative diseases and ageing, have increased in both cities and countryside³¹. For preventive management of chronic disease, it is necessary to know the information about Antioxidant Activities in commonly consumed fruits and vegetables. Reliable data on the bioactive compounds of foods for human consumption are essential for many areas of endeavor including health assessment, formulation of appropriate institutional and therapeutic diets, nutrition education, food and nutrition training, epidemiological research on the relationship between diet and diseases, plant breeding, food policy and regulation, and for a variety of application in agriculture, trade, research and development.

In recent years, there has been a great deal of research on the antioxidant capacities of fruits and vegetables in Bangladesh. Couple of research works already be done in INFS with specific vegetables^{32,33}, fruits³⁴, medicinal plants³⁵, spices³⁶ and organic and inorganic varieties of two vegetables³⁷. However, the samples of these studies were either indigenous variety or composite mixture of food. But new high yielding varieties of fruits and vegetables have been developed by utilization of modern technology of different agricultural research institutes of Bangladesh. And it becomes necessary to determine and compare the nutritive values of these new varieties and recommend varieties with highest nutritive value for production, marketing and consumption.

The present study takes an attempt to estimate and compare the Hydrophilic Antioxidant activity (AA), Vitamin C and Total Phenol Content (TPC) of selected varieties of commonly consumed fruits and vegetables of Bangladesh grown for Standard Cultivation Practice by Bangladesh Agricultural Research Institute (BARI). The result of this study will give valuable message and enrich not only nutritional area but also agricultural and public health sector as well. No such study has been found conducted with this specific issue in Bangladesh.

1.3 Objective of the study

General objective

To estimate the hydrophilic Antioxidant Activity, Vitamin C and Total Phenol Content (TPC) of selected varieties of commonly consumed fruits and vegetables of Bangladesh grown for Standard Cultivation Practice by Bangladesh Agricultural Research Institute (BARI).

Specific objectives

1. To determine the hydrophilic Antioxidant Activity (AA) of selected varieties of commonly consumed fruits and vegetables.
2. To determine the varietal differences in hydrophilic Antioxidant Activity (AA) of selected varieties of commonly consumed fruits and vegetables.
3. To determine the Total Phenol Content (TPC) of selected varieties of commonly consumed fruits and vegetables.
4. To determine the varietal differences in Total Phenol Content (TPC) of selected varieties of commonly consumed fruits and vegetables.
5. To estimate the amount of vitamin C (L-Ascorbic Acid) of selected varieties of commonly consumed fruits and vegetables by HPLC method.
6. To determine the varietal differences in vitamin C (L-Ascorbic Acid) content of selected varieties of commonly consumed fruits and vegetables.
7. To determine the correlation between hydrophilic Antioxidant Activity (AA) and Total Phenol Content (TPC) of commonly consumed fruits and vegetables and their varieties.

2.1 Introduction to antioxidant

The biological antioxidants are compounds that protect biological systems against the potentially harmful effects of processes or reactions that cause excessive oxidation. Hydrophilic compounds, such as vitamin C, thiols and flavonoids, as well as lipophilic compounds, such as Vitamin E, Vitamin A, Carotenoids and ubiquinol are the best known natural antioxidants. Many of these compounds are of special interest due to their ability to reduce the hazard caused by reactive oxygen and nitrogen species (ROS and RNS). Some are free radicals, and have been associated with lowered risks of cardiovascular^{38,39}.

2.1.1 Antioxidants and free radicals

Free radicals may naturally produce in human body and the antioxidants can neutralize the damaging effect of free radicals. Most of the times, free radicals be more numerous than the naturally occurring antioxidants. It is important to maintain the balance between antioxidant and free radical in human body for obtaining the maximum benefits of antioxidants. From the bloodstream, antioxidant helps to remove and neutralize free radicals⁴⁰.

Free radicals are unstable compounds in the body that will "do anything" to become stable, which they do by stealing an electron from another molecule. In the process they make the other molecule unstable, and by this method, they cause tissue damage, which must be repaired to maintain health. Free radicals are chemically active atoms that have a charge due to an excess or deficient number of electrons. Examples of free radicals are the superoxide anion, hydroxyl radical, transition metals such as iron and copper, nitric acid, and ozone⁴¹.

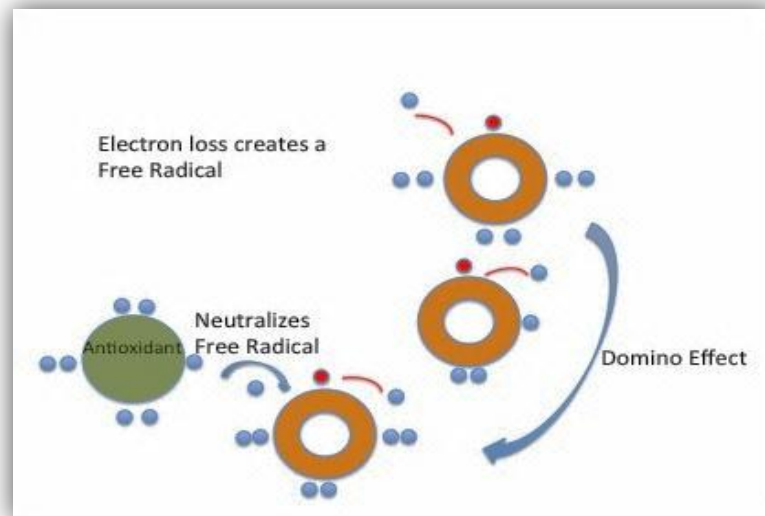

Figure 2.1: Free radical creation and neutralization

The most biologically active free radical is called reactive oxygen species (ROS). ROS include the superoxide radicals and hydroxyl radical, with oxygen derivatives. The main difference from ROS to hydrogen peroxide, singlet oxygen, hypochlorous acid is that ROS do not have any unpaired electron. But ROS have one or more unpaired electrons. For this reason they are extremely unsteady. They scavenge human body to take or donate electrons, and then damage cell⁴².

2.1.2 How Antioxidants work

The main work of Antioxidants to check the oxidation process in human body by neutralizing free radicals. During neutralization antioxidants become oxidized.

Antioxidants work in two ways:

- **Chain-breaking** -Antioxidants nutrients like beta-carotene and vitamins C and E usually follow this way to terminate the continuous chain forming process of free radicals.
- **Preventive** - Some antioxidants like antioxidant enzymes (superoxide dismutase, catalase and glutathione peroxidases) can prevent oxidation by reducing the rate of chain initiation⁴³.

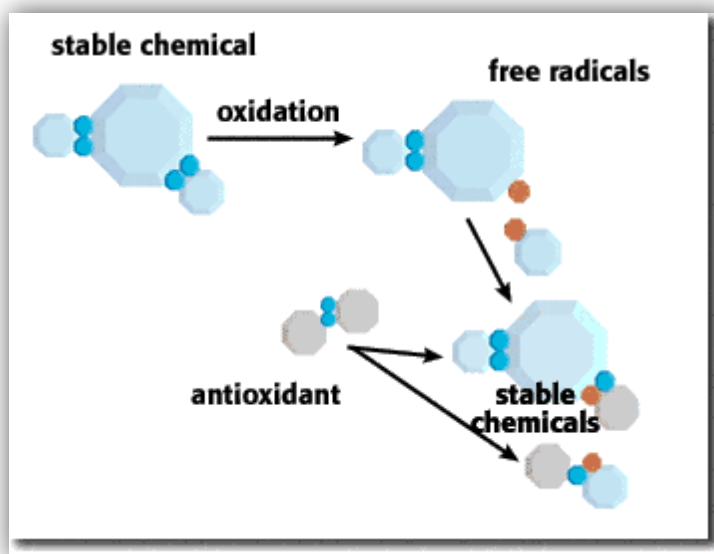

Figure 2.2: Action of antioxidant

2.1.3 Types of Antioxidants

2.1.3.1 Antioxidant nutrients

Antioxidants from our diet appear to be of great importance in controlling damage by free radicals. Each nutrient is unique in terms of its structure and antioxidant function⁴⁴.

- **Vitamin C:** It scavenges free radicals that are in an aqueous (watery) environment, such as inside our cells. Vitamin C works synergistically with vitamin E to quench free radicals. Vitamin C also regenerates the reduced (stable) form of vitamin E.
- **Vitamin E:** Alpha-tocopherol, the most widely available isomer, has the highest biopotency or strongest effect in the body. Because it is fat-soluble (and can *only* dissolve in fats), alpha-tocopherol is in a unique position to safeguard cell membranes -- largely composed of fatty acids -- from damage by free

radicals. Alpha-tocopherol also protects the fats in low-density lipoproteins (LDLs, or the "bad" cholesterol) from oxidation.

- **Beta-carotene:** There are 600 carotenoids identified. It is thought to be the best quencher of singlet oxygen (an energized but uncharged form of oxygen that is toxic to cells). Beta-carotene is also especially excellent at scavenging free radicals in low oxygen concentration.
- **Selenium** It forms the active site of several antioxidant enzymes including glutathione peroxidase.

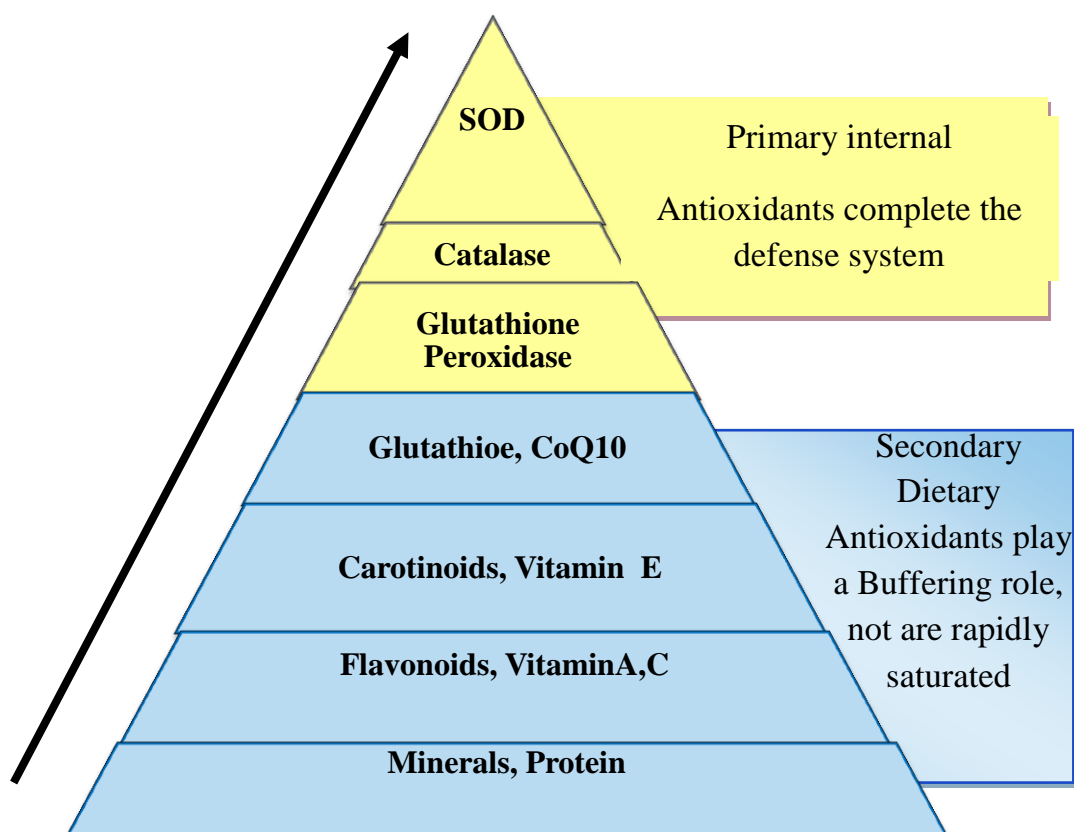

Figure 2.3: Increasing protective effect of antioxidant nutrients and enzymes

2.1.3.2 Antioxidant enzymes

Antioxidant Enzymes **Superoxide dismutase (SOD)**, **Catalase (CAT)**, **Glutathione peroxidase (GPx)** serve as primary line of defense in destroying free radicals.

SOD first reduces (adds an electron to) the radical superoxide (O_2^-) to form hydrogen peroxide (H_2O_2) and oxygen (O_2).



Catalase and GPx then work simultaneously with the protein glutathione to reduce hydrogen peroxide and ultimately produce water (H_2O).

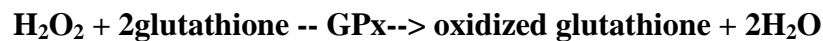

2.1.4 Health benefits of Antioxidants

Antioxidants benefit the health by scavenging free radicals in bloodstream. The health benefits of antioxidants are:

- Antioxidants can support kidney function, immune and respiratory system & can improve defense power of the body.
- They improve reproductive function, nervous system functioning and also quality of sleep.
- They maintain good dental health and healthy vision.
- They protect liver and prevent digestive disorder.
- They can reduce obesity and have anti-ageing effect.
- They can even protect the skin from sun damage, and reduce the incidence of sunburn.

Although antioxidants aren't proven to treat any conditions, research has shown that antioxidants have also been implicated in the prevention of a number of degenerative, age-related diseases, including⁴⁵:

- Cancer
- Cardiovascular disease
- Cognitive impairment
- Immune dysfunction
- Cataracts
- Macular degeneration
- Alzheimer's

2.1.5 RDAs for dietary antioxidants

Since the last publication of the RDAs in 1989, the Food and Nutrition Board (FNB) has changed the criteria for establishing RDAs from prevention of deficiency diseases to prevention of chronic diseases. Recently published revised RDAs by the FNB is based on the prevention of deficiency symptoms has little difference from the previous one (based on the prevention of chronic diseases)⁴⁶.

Table 2.1: The new and old RDA of the dietary antioxidants for the adults (19 years and older)

Antioxidants	The new RDA		The old RDA	
	Men	Women	Men	Women
Vitamin C	90 mg/day	75 mg/day	60 mg/day	60 mg/day
vitamin E	15 mg/day	15 mg/day	10 mg/day	8 mg/day
Selenium	55 µ/day	55 µ/day	70 µ/day	55 µ/day
beta-carotene and other carotenoids	No references	No references	No references	No references

2.1.6 Sources of Antioxidants in food

Plant foods are rich sources of antioxidants. They are most abundant in fruits and vegetables, as well as other foods including nuts, whole grains and some meats, poultry and fish⁴⁷.

Good sources of specific antioxidants include:

- vitamin A – liver, sweet potatoes, carrots, milk, and egg yolks
- vitamin C – oranges, blackcurrants, kiwifruit, mangoes, broccoli, spinach, capsicum and strawberries
- vitamin E – vegetable oils (such as wheat germ oil), avocados, nuts, seeds and whole grains
- beta-carotene – pumpkin, mangoes, apricots, carrots, spinach and parsley
- lycopene – tomatoes, pink grapefruit and watermelon
- cryptoxanthins – red capsicum, pumpkin and mangoes
- selenium – seafood, offal, lean meat and whole grains
- zinc – seafood, lean meat, milk and nuts
- copper – seafood, lean meat, milk and nuts
- manganese – seafood, lean meat, milk and nuts
- polyphenols – thyme and oregano
- flavonoids – tea, green tea, citrus fruits, red wine, onion and apples
- isoflavonoids – soybeans, tofu, lentils, peas and milk
- allium sulphur compounds – leeks, onions and garlic
- anthocyanins – eggplant, grapes and berries
- catechins – red wine and tea
- indoles – cruciferous vegetables such as broccoli, cabbage and cauliflower
- lignans – sesame seeds, bran, whole grains and vegetables
- lutein – green, leafy vegetables like spinach, and corn
- zoochemicals – red meat, offal and fish. Also derived from the plants that animals eat.

2.1.7 High-dose antioxidant supplements

High-dose vitamin E supplements are sometimes responsible for prostate cancer and hemorrhagic stroke and may rise the risk of bleeding inhuman. Some research works recommend that antioxidant supplementation is helpful during cancer treatment hence, some studies suggested the opposite.

2.2 Introduction to phenolic compounds

Several hundreds of different polyphenols have been identified in foods. They comprise a wide variety of molecules that have a polyphenol structure (i.e. several hydroxyl groups on aromatic rings), but also molecules with one phenol ring, such as phenolic acids and phenolic alcohols. All plant based foods have phenols, which affect their appearance, taste, odor and oxidative stability. Polyphenols are divided into several classes; the main groups of polyphenols are: flavonoids, phenolic acids, phenolic alcohols, stilbenes and lignans^{48,49}.

2.2.1 Phenolic compounds

Several different routes are involved for the biosynthesis of phenolic compounds. The two basic pathways are:

- **Shikimic acid pathway**- most of the plant phenolics are biosynthesized by this pathway.
- **Malonic acid pathway**-important source of phenolic secondary products in lower plants.

The general breakdown of plant-based phenols is given following page (Fig-2.4).

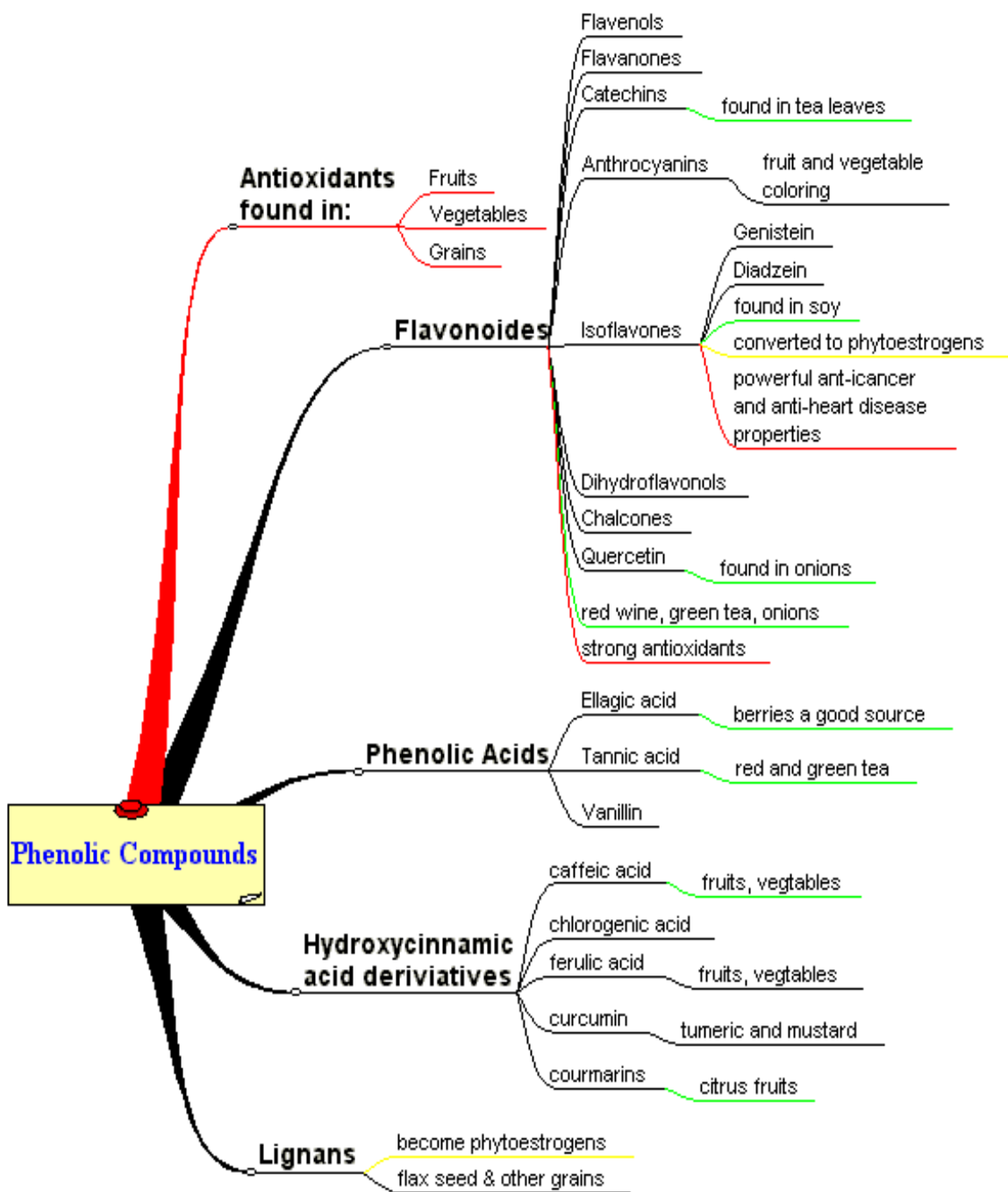

Figure 2.4: The general breakdown of plant-based phenols

2.2.2 Phenolic compounds and their sources

Flavonoids: Flavonoids share a common carbon skeleton of diphenyl propanes, two benzene rings joined by a linear three carbon chain. The central three carbon chain may form a closed pyran ring with one of the benzene rings. Flavonoids are themselves distributed among several classes, depending on the oxidation state of the central pyral ring: flavonols, flavones, flavanones, isoflavones, anthocyanidins and flavanols.

Flavonols: The common sources of flavonols are:

- Onions
- Broccoli
- Blueberries
- Tea and red wine

Flavones: They are the less common flavonoids. Only Parsley and celery are the common sources of flavones.

Flavanones: High concentration of flavanones is present only in citrus fruit. But it is also found in tomato and mint⁵⁰.

Isoflavones: Legumes are the exclusive source of isoflavones. They are present in

- Soybeans (contain between 140 and 1530 mg isoflavones/kg fresh wt) and
- Soya milk(contain between 12 and 130 mg/L⁵¹⁻⁵². isoflavones/kg fresh wt)

Anthocyanins: They occur primarily as glycosides of their respective aglycones form, called anthocyanidins. They are widely distributed in human diet; such red wine, cereals, vegetables but they are very common in fruit.

Flavanols: They are not glycosylated in foods. The main sources of flavanols are fruit and tea.

Phenolic acids: One of the most common phenolic acids is caffeic acid, present in many fruits and vegetables, most often esterified with quinic acid as in chlorogenic acid, which

is the major phenolic compound in coffee. Another common phenolic acid is ferulic acid, which is present in cereals and is esterified to hemicelluloses in the cell wall.

Phenolic alcohols: Tyrosol (4-hydroxy phenylethanol) and hydroxyl tyrosol (3,4-dihydroxy phenylethanol) are the main phenolic alcohols. They are contained mainly in extra virgin olive oil (40.2 and 3.8 mg/kg respectively). Tyrosol is also present in red and white wines and beer⁵³.

Stilbenes: low quantities of stilbenes are present in the human diet and the main representative is resveratrol. It has been detected in more than 70 plant species, including grapes, berries and peanuts. The fresh skin of red grapes is particularly rich in resveratrol (50-100 g/kg net weight) which contributes to a relatively high concentration of resveratrol in red wine and grape juice

Lignans: linseed represents the main dietary source, containing up to 3.7g/kg dry wt of secoisolariciresinol. Intestinal microflora metabolizes lignans to enterodiol and enterolactone⁵⁴.

Most of these compounds have received considerable attention as potentially protective factors against human chronic diseases (cataract, muscular degeneration, diabetes mellitus, cancer, and cardiovascular disease and neurodegenerative diseases).

Most recent screening of the Bangladeshi indigenous and commonly consumed foods for their health beneficial role, that is, total polyphenol content, anti-oxidant, anti-inflammatory and anti-allergic roles showed that significant number of foods has *in vitro* anti-inflammatory and anti-allergic activity and also showed higher Oxygen Radical Absorbance Capacity (ORAC) value, e.g. Tea, spices, fruits etc⁵⁵

2.2.3 Polyphenols: food sources and bioavailability⁵⁶

Table 2.2: Polyphenols in foods

Name of Polyphenols present in foods	Source (serving size)	Content of Polyphenol	
		By wt or vol (mg/kg FW or mg/L)	By serving (mg/serving)
Hydroxybenzoic acid (2,6)	Blackberry(100g)	80-270	8-27
Hydroxycinnamic acid (2, 5-7)	Blueberry (100g)	2000-2200	200-220
Coumaric acid	Plum (200g)	140-1150	28-230
Ferulic acid	Aubergine (200g)	600-660	120-132
Sinapic acid	Apple (200g)	50-600	10-120
Anthocyanins (8-10)	Aubergine (200g)	7500	1500
Cyanidin	Blackberry(100g)	1000-4000	100-400
Flavonols (11-18)	Yellow onion (100g)	350-1200	35-120
Quercetin	Curly Kale (200g)	300-600	60-120
Kaempferol	Leek (200g)	30-225	6-45
Myricetin	Cherry Tomato (200g)	15-200	3-40
	Broccoli (200g)	40-100	8-20
	Beans (200g)	10-50	2-10
	Tomato (200g)	2-15	0.4-3.0
Flavones (11-12, 14, 18)	Parsley (5g)	240-1850	1.2-9.2

Apigenin	Celery (200g)	20-140	4-28
Flavanones (19-21)	Orange juice (200mL)	215-685	40-140
Isoflavones (22-25)	Soy flour (75g)	800-1800	60-135
Daidzein	Soybeans, boiled (200g)	200-900	40-180
Genistein	Miso (100g)	250-900	25-90
Monomeric flavanols (6, 17, 26, 27)	Chocolate (50g)	460-610	23-30
Catechin	Beans (200g)	350-550	70-110
Epicatechin	Grape (200g)	30-175	6-35
	Blackberry (100g)	130	13
	Apple (200g)	20-120	4-24
	Green tea (200 mL)	100-800	20-160
	Black tea (200mL)	60-500	12-100

This table is adapted from the article Manach C, Scalbert A, Morand C, Rémésy C, Jiménez L. Polyphenols: food sources and bioavailability. *Am J Clin Nutr.* 2004; 79: 727–47

2.2.4 Protection by dietary polyphenols

Dietary polyphenols has protective factors against different diseases. They can scavenge reactive oxygen species (ROS) because they have strong antioxidant properties⁵⁷. They can protect human prostate cells, colon cancer cells, hepatocytes, leukemia cells, breast cancer cells, and oral epithelial cells⁵⁸. They have-

- antioxidant effects,
- cardio and hepatoprotective effects,
- anticarcinogenic effects,
- antimicrobial and antiviral effects, and
- anti-inflammatory effects^{59,60}.

Different biological processes in human body are affected by polyphenols, such as:

- altered gene expression,
- increased apoptosis,
- decreased platelet aggregation,
- increased blood vessel dilation,
- modulated intercellular signaling,
- P-glycoprotein activation, and
- modulation of enzyme activities associated with carcinogen activation and detoxification⁶¹.

Again, they work as chelating agent, ie, iron, decreasing their ability to promote ROS formation through Fenton chemistry^{62,63}.

2.2.5 Classification and structures of phenolic compounds

The general classification of phenolic compounds is presented in the following page:

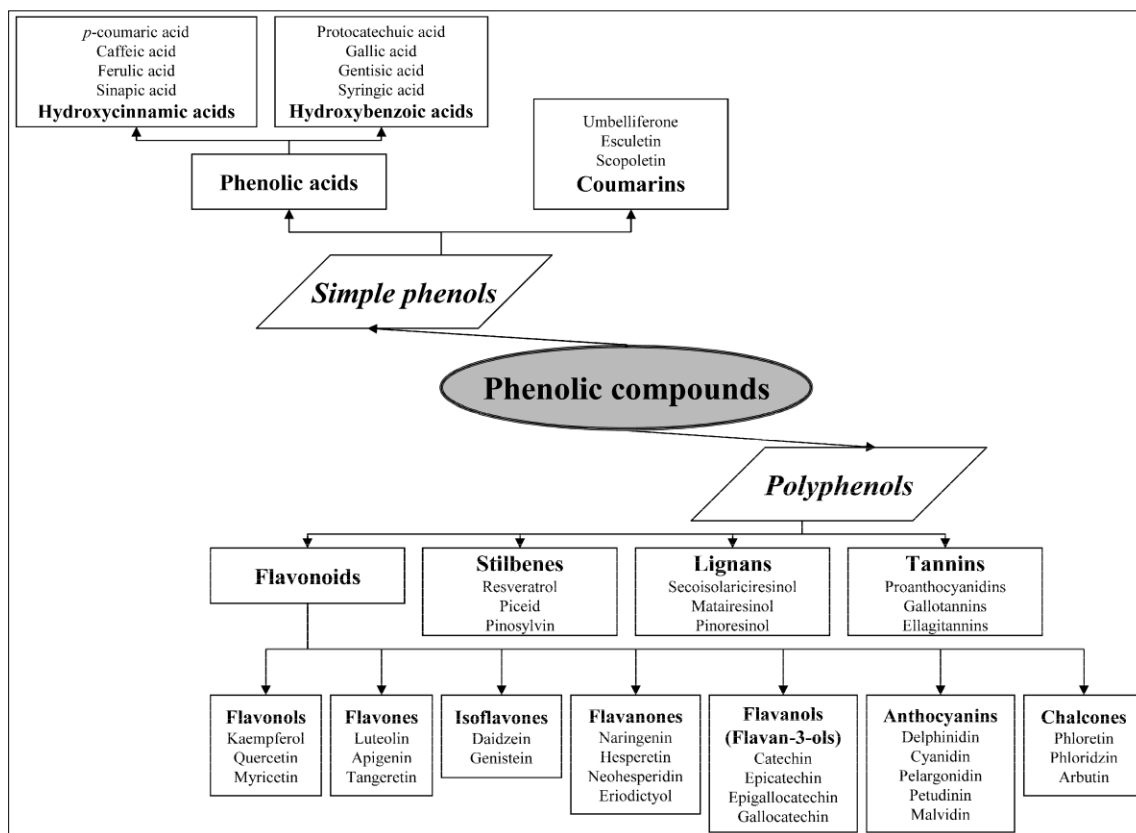

Figure 2.5: Classification of phenolic compounds

Phenolic compounds, or polyphenols, constitute one of the most numerous and widely-distributed groups of substances in the plant kingdom. More than 8,000 phenolic structures were currently known. They produced from the secondary metabolism of plants. They have an aromatic ring with one or more hydroxyl substituent. Table- 2.3 represents the major classes of plant polyphenol⁶⁵.

Table 2.3: The major classes of phenolic compounds in plants⁶⁵

Number of carbon atoms	Basic skeleton	Class	Examples
6	C6	Simple phenols Benzoquinones	Catechol, hydroquinone 2,6-Dimethoxybenzoquinone
7	C6-C1	Phenolic acids	Gallic, salicylic
8	C6-C2	Acetophenones Tyrosine derivatives Phenylacetic acids	3-Acetyl-6-methoxybenzaldehyde Tyrosol p-Hydroxyphenylacetic
9	C6-C3	Hydroxycinnamic acids Phenylpropenes Coumarins Isocoumarins Chromones	Caffeic, ferulic Myristicin, eugenol Umbelliferone, aesculetin Bergenon Eugenin
10	C6-C4	Naphthoquinones	Juglone, plumbagin
13	C6-C1-C6	Xanthones	Mangiferin
14	C6-C2-C6	Stilbenes Anthraquinones	Resveratrol Emodin
15	C6-C3-C6	Flavonoids Isoflavonoids	Quercetin, cyanidin Genistein
18	(C6-C3) ₂	Lignans Neolignans	Pinoresinol Eusiderin
30	(C6-C3-C6) ₂	Biflavonoids	Amentoflavone
n	(C6-C3) _n (C6) _n (C6-C3-C6) _n	Lignins Catechol melanins Flavolans (Condensed Tannins)	

Table 2.3 is adapted from the article -Harborne J B. Plant phenolics. In: Bell EA, Charlwood BV (eds). Encyclopedia of Plant Physiology, volume 8. Secondary Plant Products, Springer-Verlag, Berlin Heidelberg New York. 1980; 329-395

Figure 2.6 shows the basic structure and the system used for the carbon numbering of the flavonoid nucleus. Structural variations within the rings subdivide the flavonoids into several families: flavonols, flavones, flavanols, isoflavones, anthocyanidins and others. These flavonoids often occur as glycosides, glycosylation rendering the molecule more water-soluble and less reactive toward free radicals. The sugar most commonly involved in glycoside formation is glucose, although galactose, rhamnose, xylose and arabinose also occur, as well as disaccharides such as rutinose. The flavonoid variants are all related by a common biosynthetic pathway, incorporating precursors from both the shikimate and the acetate-malonate pathways⁶⁶. Further modification occurs at various stages, resulting in an alteration in the extent of hydroxylation, methylation, isoprenylation, dimerization and glycosylation (producing O- or C-glycosides). Phenolic compounds act as antioxidants with mechanisms involving both free radical scavenging and metal chelation. They have ideal structural chemistry for free radical-scavenging activities⁶⁷.

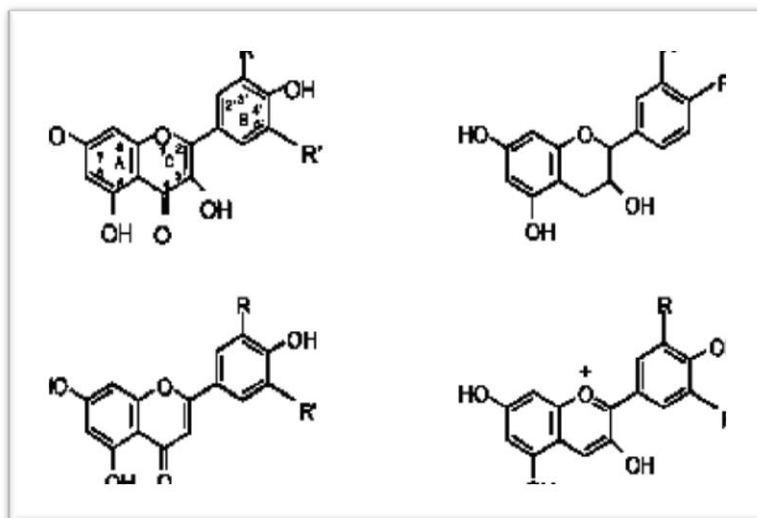

Figure 2.6: Basic structure of Flavonoids (C6-C3-C6)

The starting point for all products is 4-hydroxy-cinnamic acid (p-coumaric acid) which derives from phenylalanine; 4-hydroxycinnamic acid may be further substituted in the 3

and 5 positions by hydroxyl or methoxyl groups to yield caffeic, ferulic and sinapic acids- compounds ubiquitous in plant tissues. A variety of compounds, such as benzoic acid and derivatives, styrenes, acetophenones and gingerols, are formed from hydroxycinnamic acid by chain shortening or lengthening without ring formation. Higher molecular weight compounds are formed either by a radical driven coupling of hydroxycinnamyl units to form the lignins, or by series of condensation reactions with malonyl residues to give the xanthenes, stilbenes and flavonoids.

2.2.6 Flavonoids and other phenolic compounds

These are found in fruits, vegetables, coffee, tea and alcoholic beverages. Over 2000 individual flavonoids have been described. The class includes flavones, flavonols and flavonones; most occur in nature as glycosides. Quercetin, kaemferol and myricetin are flavonols widely distributed in berries, tomatoes, potatoes, broad beans, broccoli, squash and onions; radishes, kale and endive are rich in kaemferol⁶⁸. Flavonoids act as antioxidants and metal chelators. By protecting low density lipoprotein (LDL) cholesterol from oxidation and by inhibiting platelet aggregation, flavonoids may protect against heart disease. Unlike plant alkaloids, flavonoids are generally considered to be non-toxic. Phenolic compounds are also involved in the induction of detoxification systems, and some inhibit N-nitrosation reactions by trapping nitrate to C-nitrosophenolic compounds. Important simple phenolic molecules, found in freshly harvested vegetables and fruits and in teas, wines, caffeic, ellagic and ferulic acids and their respective glycosides⁶⁹.

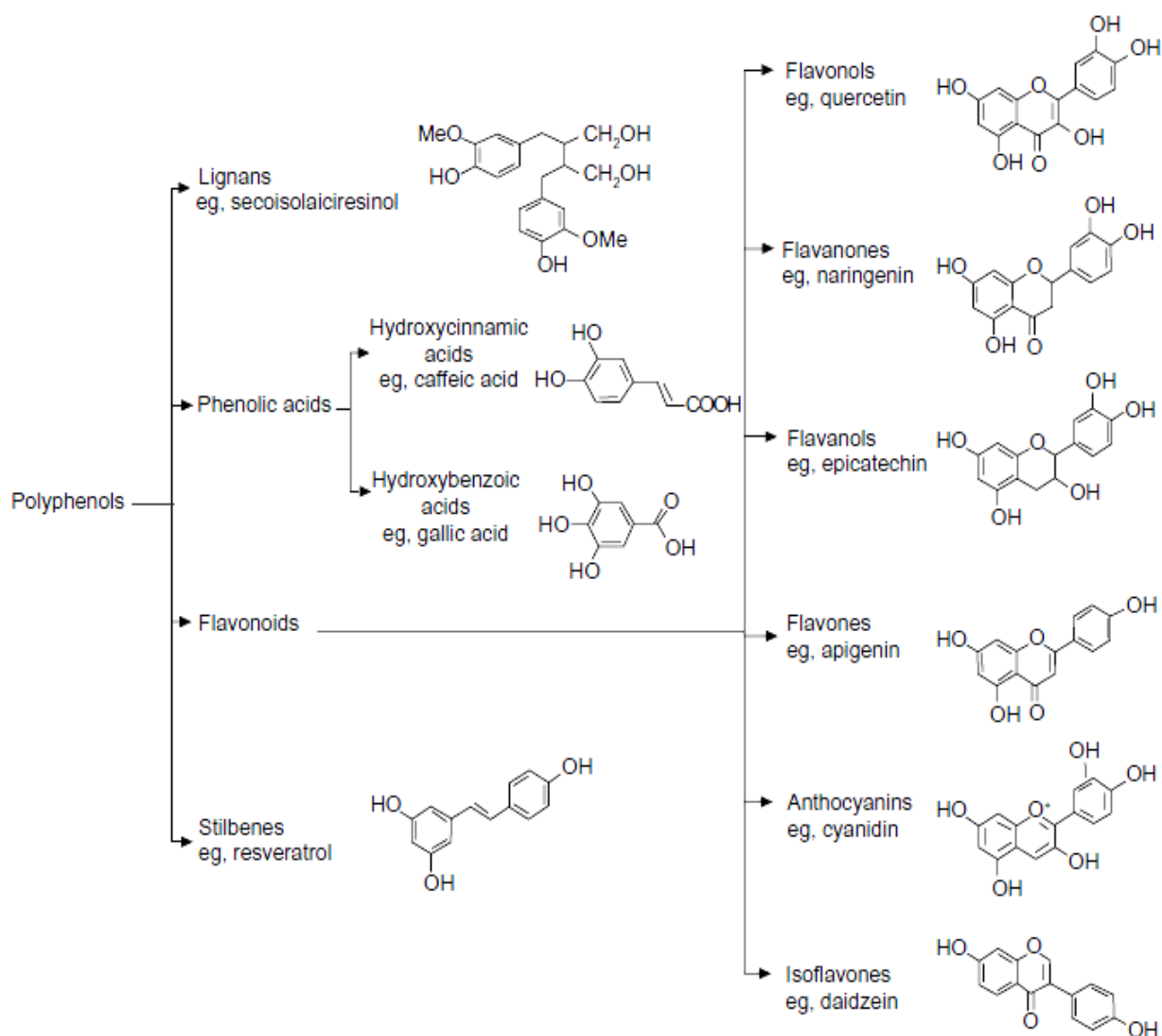

Figure 2.7: Classification and chemical structure of major classes of dietary polyphenols.

As a chemical family, polyphenols can be divided into at least 10 different classes depending on their basic chemical structure (Figure 2.7). The most common and important low molecular weight phenolic compounds are simple phenolic derivatives and flavonoids.

2.2.6.1 Quercetin

Quercetin is a flavonoid and, to be more specific, a flavonol. It is the glycone form of a number of other flavonoid glycosides, such as rutin and quercitrin, found in citrus fruit, buck wheat and onions. It helps to prevent cancer⁶⁹.

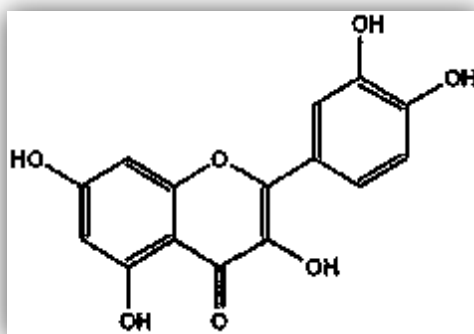

Figure 2.8: Quercetin

2.2.6.2 Epicatechin

Cocoa, the major ingredients of dark chocolate, contains relatively high amount of epicatechin and has been found to have nearly twice the antioxidant content of red wine and up to three times that of green tea. Epicatechin improves blood flow and thus seems good for cardiac health⁷⁰.

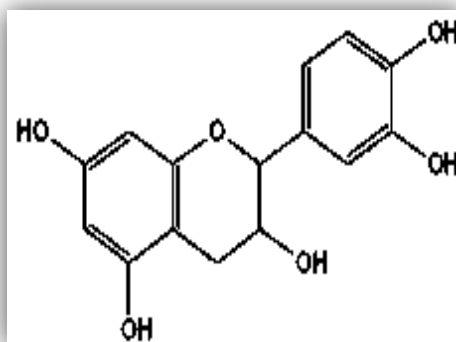

Figure 2.9: Epicatechin

2.2.6.3. Tannins

Proanthocyanidins extracts demonstrate a wide range of pharmacological activity. Their effects include increasing intracellular vitamin C levels, decreasing capillary permeability and fragility, scavenging oxidants and free radicals and inhibiting destruction of collagen, the most abundant protein in the body⁷⁰.

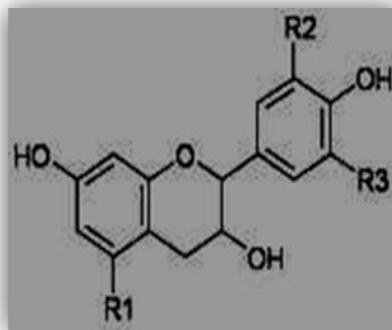

Figure 2.10: Tannins

2.2.6.4. Chalcone

Chalcone is an aromatic ketone that forms the central core for a variety of important biological compounds, which are known collectively as chalcone. They show antibacterial, antifungal, antitumor and anti-inflammatory properties. Some chalcones demonstrated the ability to block voltage dependent potassium channels. They are also intermediates in the biosynthesis of flavonoid^{55, 70}.

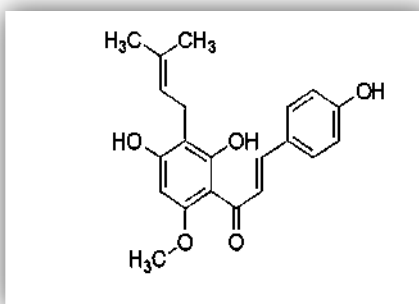

Figure 2.11: Chalcone

2.2.7 Phenolic acids

Phenolic acids are derivatives of benzoic and cinnamic acids and are present in all cereals, freshly harvested vegetables, fruits, tea and in wines. There are two classes of phenolic acids: hydroxybenzoic acids and hydroxycinnamic acids. Hydroxybenzoic acid contains Gallic acids, p-hydroxybenzoic, vanillin, syringic, and protocatechic acids.

The major phenolic acids are ferrulic and p-coumeric acids^{55,70}.

2.2.8. Avenanthramides

Avenanthramides consist of an anthranilic acid derivative linked to a hydroxycinnamic acid derivative. Its level range from 40-132 µg/g in the grain; they are heat stable during processing³¹. These compounds are bioavailable, and they have anti-inflammatory, anti-antherogenic and antioxidant properties⁶⁵⁻⁶⁶.

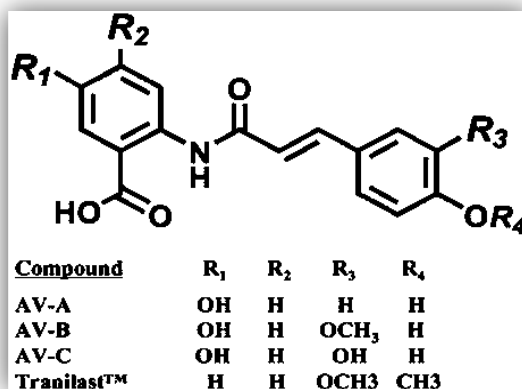

Figure 2.12: Avenanthramides

2.2.9 Lignans

They mainly found in flax seed. They work as antioxidants. The plant lignans identified are seciisolarciresinol and matairesinol. When ingested these two are converted into the mammalian lignans known as enterodiol and enterolacton⁷¹ by intestinal bacteria.

2.2.10 Catechins

Tea (*Camellia sinensis*) extracts are rich in phenolics related to catechins. In green tea, made from fresh leaves, epicatechin and epigallocatechins predominate. In black teas the catechins are oxidized in theaflavins and water insoluble thearubigins. Both green and black teas are claimed to have antihypertensive effects. Tea poly phenols inhibit the action of angiotensin I-converting enzyme, preventing the formation of the vasoconstriction angiotensin II.⁷¹

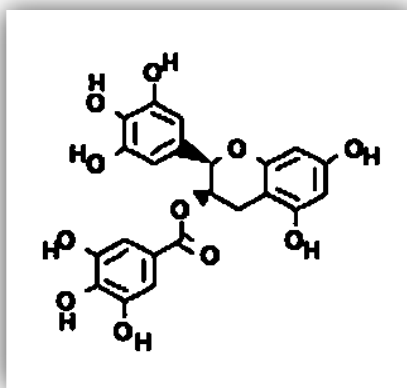

Figure 2.13: Catechin

2.2.11 Gingerol

Ginger has traditionally been used medicinally as carminative (to relieve flatulence) and stimulant. In recent studies it has been shown that ginger ameliorates symptoms of pain and swelling in musculoskeletal disorders⁷².

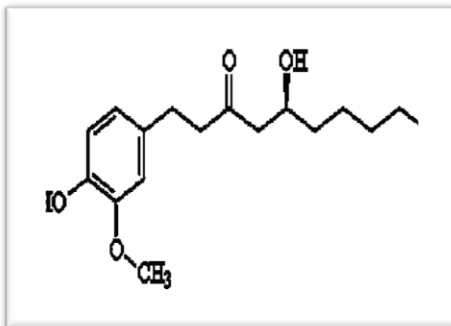

Figure 2.14: Gingerol

2.2.12 Coumerins

These have a variety of anti-coagulatory and anti-inflammatory properties. They are found in vegetables, citrus fruits and some herbs. Dicoumerol inhibit the synthesis of other vitamin-K dependent coagulation factors. A small numbers of experimental studies show that it inhibits chemically induced cancer of stomach and breast ⁷³.

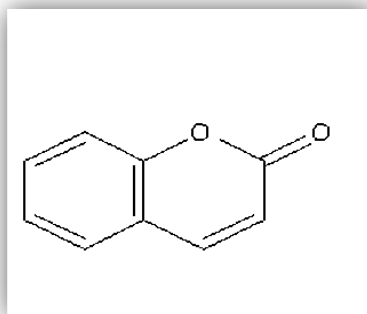

Figure 2.15: Coumerin

2.2.13 Dietary intake of plant polyphenols

Plant polyphenols are commonly consumed mostly from fruits, vegetables, legumes, wine and tea. Although widespread in the food supply, the quantification of dietary polyphenol content and estimated dietary intake has been complicated by several factors. Besides plant variety, many other factors are important in determining polyphenol concentrations of specific food products in the food supply, including production method (organic/conventional), annual climatic variations, and post-harvest processing and

storage⁷⁴. The cooking method can also affect the polyphenol content of foods since polyphenols are present in plant vacuoles and apoplasts, cellular structures that require softening during the cooking process to maximize polyphenol release⁷⁵. Although dietary consumption of polyphenols is high, the risk of toxicity from the food supply is relatively low, largely due to poor absorption. However, concentrations of dietary bioactive agents can be significantly increased, and presumably absorption as well, through food-based polyphenol enrichment, alterations in bioavailability, and supplementation with purified agents or mixtures rendering polyphenol consumption potentially problematic.

2.2.14 Bioavailability of polyphenol compounds

The critical importance of bioavailability in conferring additional benefit or toxicity depends on increased absorption of polyphenols. This has fostered categorization of polyphenols as readily absorbed or not, alternately defined as extractable or non-extractable⁷⁶. Extractable polyphenols are low to intermediate molecular weight phenolics, which can be extracted with different, commonly used solvents such as water or methanol. Non extractable polyphenols are high molecular weight compounds that can bind dietary fiber or protein and remain insoluble in the aforementioned solvents. As such, they tend to be relatively resistant to intestinal digestion and/or absorption and are readily excreted in feces. An additional consideration is that degradation and absorption of polyphenols within the gastrointestinal tract depend on the intestinal micro flora and gut enzymes, which may significantly change bioavailability.

2.2.15 Intestinal absorption and metabolism

In foods, all flavonoids except flavanols are found in glycosylated forms which can help the absorption of food. But their actual work in stomach is yet unknown. They and glycosylation influences absorption. Some flavonoids, such as quercetin and daidzein, but not for their glycosides^{77,78}.

2.2.16 Metabolism by the gut micro flora

In human stomach unabsorbed polyphenol is carried to the colon in the form of small bowl (Fig 2.16). Some intestinal micro flora involved in its physiological process. In addition, polyphenols that are absorbed, metabolized in the liver and excreted in the bile or directly from the enterocyte back to the small intestine will also reach the colon but in a different chemical form, such as a glucuronide^{79,80}.

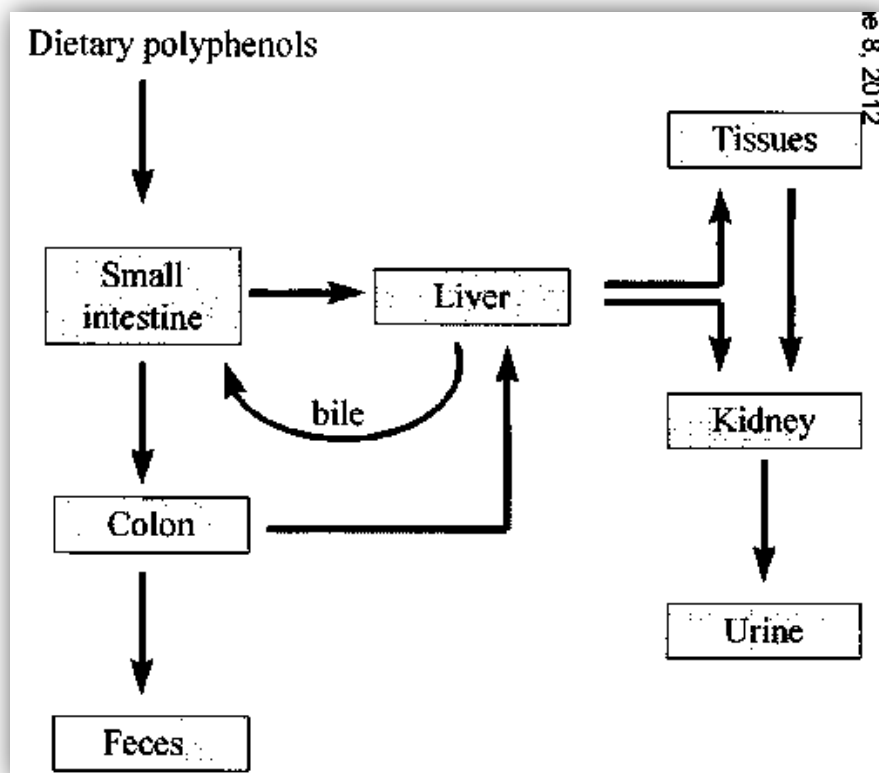

Figure 2.16: Possible routes for consumed polyphenols in humans

2.2.17 Plasma transport and partitioning into lipid structures

During Polyphenol metabolism in the blood, some components are involved, such as

- Plasma proteins (99% for concentrations up to 15 $\mu\text{mol/L}$),
- VLDL (<0.5%).
- Albumin-binding material. Structure of polyphenol may differ with the affinity to Albumin. eg..ferulic and coumaric acids, have a low affinity⁸¹

- Some polyphenols penetrate the lipophilic membrane indifferent amount⁸²⁻⁸⁶. LDL, a very small quantity of plasma polyphenols are associated with the LDL^{87,88}. Some polyphenols have ionic interactions with charged residues on the surface of the particles.

2.2.18 Plasma concentrations

According to the nature of the polyphenol and the food source, plasma concentrations may vary after polyphenol consumption. eg. Polyphenols come from the green tea, apples, onions, cocoa, red wine are quickly dissolved in plasma⁸⁹⁻⁹¹.

2.2.19 Tissue uptake

It is important to determine the actual bioavailability of polyphenol metabolites in tissues. Different studies have conducted to estimate actual bioavailability of polyphenol metabolites in tissue by HPLC analysis in different tissues in mice and rats, including brain^{92,93}, endothelial cells⁹⁴, heart, kidney, spleen, pancreas, prostate, uterus, ovary, mammary gland, testes, bladder, bone, and skin⁶⁹⁵⁻⁹⁸. The concentrations obtained in these tissues ranged from 30 to 3000 ng aglycone equivalents/g tissue depending on the dose administered and the tissue considered. Youdim et.al⁹⁹ showed that the uptake of flavanone glucuronides by rat and mouse brain endothelial cultured cells is much lower than that of their corresponding aglycones.

2.2.20 Elimination

There are 2 pathways of excretion of the metabolites of polyphenols. They are

1. The biliary route (Large, extensively conjugated metabolites are excreted)
2. The urinary route (Small conjugates such as mono sulfates are preferentially excreted).

There is a correlation between the total amount of metabolites excreted in urine and maximum plasma concentrations. High excretion is also depend on amount food source. High excretion for flavanones from citrus fruit (4–30% of intake), for naringenin from grapefruit juice¹⁰²⁻¹⁰⁶, for isoflavones: the percentages excreted are 16– 66% for daidzein and 10–24% for genistein¹⁰⁷⁻¹¹¹.

2.2.21 Protection by dietary polyphenols

Using diverse *in vitro* cellular models, polyphenols exhibit powerful antioxidant activities and have been consistently protective through scavenging numerous diverse reactive oxygen species (ROS) including hydroxyl radical, peroxy radical, hypochlorous acid, superoxide anion, and peroxynitrite^{112,113}. Examples of cell models previously used include human prostate cells, colon cancer cells, hepatocytes, leukemia cells, breast cancer cells, and oral epithelial cells¹¹⁴. Mechanisms of action have included antioxidant effects, cardio- and hepatoprotective effects, anticarcinogenic effects, antimicrobial and antiviral effects, and anti-inflammatory effects^{115, 116}. Although the most frequently reported benefit of polyphenols involves their antioxidant activity, there are numerous other biological processes that are affected by polyphenols. For example such processes include; altered gene expression, increased apoptosis, decreased platelet aggregation, increased blood vessel dilation, modulated intercellular signaling, P-glycoprotein activation, and the modulation of enzyme activities associated with carcinogen activation and detoxification¹¹⁷. Additionally, polyphenols can chelate transition metals, ie, iron, decreasing their ability to promote ROS formation through Fenton chemistry^{118,119}.

2.2.22 Antioxidant properties of polyphenols

Antioxidants present in food can help limit this damage by acting directly on ROS or by stimulating endogenous defense systems. The phenolic groups in polyphenols can accept an electron to form relatively stable phenoxyl radicals, thereby disrupting chain oxidation reactions in cellular components¹²⁰.

2.2.23 Polyphenols and Human Diseases

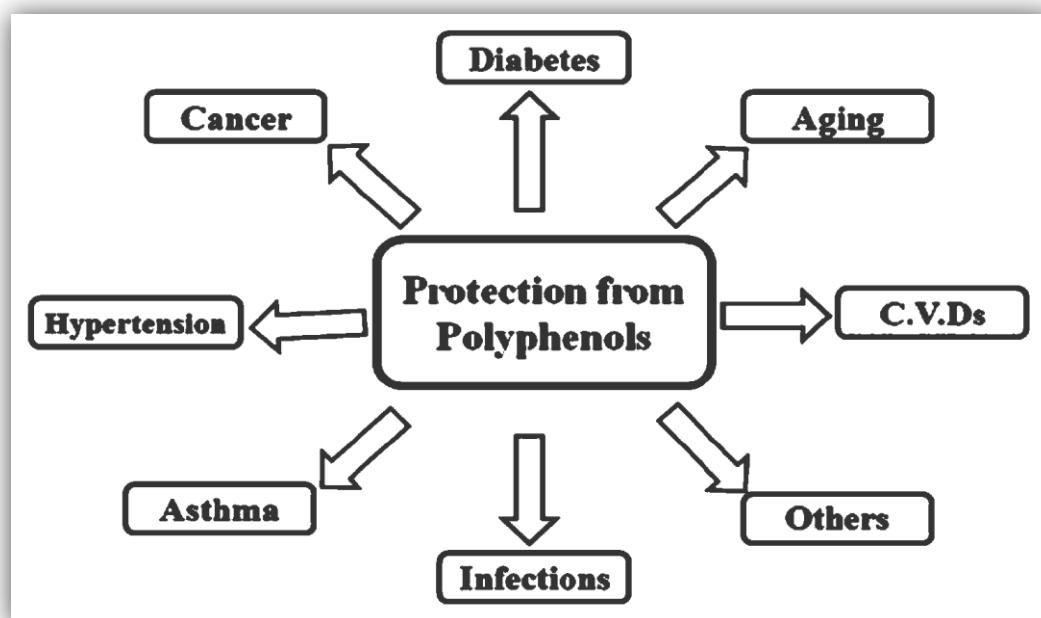

Figure 2.17 Pleiotropic health beneficial effects of dietary plant polyphenols

Polyphenols are naturally occurring compounds found largely in the fruits, vegetables, cereals and beverages. Researchers have explored that these molecules are very good antioxidants and may neutralize the destructive reactivity of undesired reactive oxygen/nitrogen species produced as byproduct during metabolic processes in the body. Many epidemiological studies have shown that polyphenols have major protective function against the development of the following diseases:

- Cardiovascular diseases
- Cancer,

- Diabetes,
- Infections,
- Aging,
- Asthma etc.

Polyphenol-rich foods and beverages may increase plasma antioxidant capacity. A Study revealed that Polyphenol-rich foods and beverages indicating the protective effects of polyphenols¹²¹.

2.2.23.1 Cardio-Protective Effect

Polyphenols have cardio-protective effects and can limit the following diseases:

- Incidence of coronary heart diseases¹²²⁻¹²⁴.
- Development of atherosclerosis¹²⁵.
- Disruption of atherosclerotic plaques¹²

Polyphenols may also exert antithrombotic effects by means of inhibiting platelet aggregation. Resveratrol, an active compound in red wine is attributed for “French Paradox”, the low incidence of CVD despite the intake of high-fat diet and smoking among French¹²⁷⁻¹²⁸.

2.2.23.2 Anti-Cancer Effect

Polyphenols work on human cancer cell lines can protect reduction the number of tumors or their growth developed in different sites of human body like mouth, stomach, duodenum, colon, liver, lung, mammary gland or skin¹²⁹. These effects have been observed at various sites, including. Many polyphenols, such as quercetin, catechins, isoflavones, lignans, flavanones, ellagic acid, red wine polyphenols, resveratrol and curcumin have anti-cancer effect¹³⁰.

Multiple mechanisms are involved to inhibit the development of carcinogenesis by dietary polyphenols (Fig. 2.18). Tea polyphenols plays important role in inhibition of cell growth and induction of apoptosis Tea consumption and genistein demonstrated anti angiogenic activity in NNK-induced lung adenoma ¹³¹ and Lewis lung xenograft ¹³² mouse models, respectively.

It is evident the role of tea polyphenols and curcumin in inhibition of arachidonic acid metabolism ^{133,134}, this action may play role in inhibition of carcinogenesis.

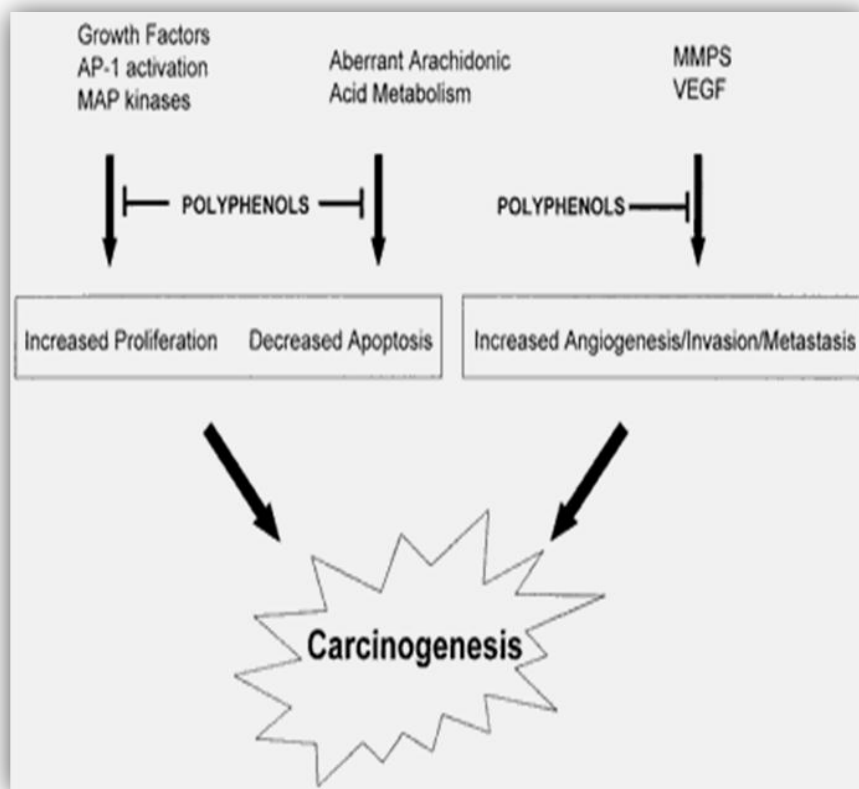

Figure 2.18: Proposed mechanistic scheme for the prevention of cancer by dietary polyphenols

2.2.23.3 Anti-Diabetic Effect

Many reports conclude that many polyphenols especially tea catechins contain antidiabetic effects^{135,136} Polyphenols may affect glycemia by maintaining the following different mechanisms:

- Inhibition of glucose absorption in the gut
- Inhibition of its uptake by peripheral tissues.
- Inhibition of intestinal glycosidases and glucose transporter¹³⁷.
- Some individual polyphenols decrease S-Glut-1 mediated intestinal transport of glucose.
- Saponins can play role in delaying the transfer of glucose from stomach to the small intestine¹³⁸.
- Onion polyphenols, especially Quercetin significantly protected the lipid peroxidation and inhibition antioxidant system in diabetics¹³⁹.

2.2.23.4 Anti-Aging Effect

Free radical/oxidative stress theory is one of the most accepted theories¹⁴⁰ to explain the mechanism of aging. Polyphenol compounds found in fruits and vegetables may show efficacy as anti-aging compound^{141,142}. It is reported that the dietary supplementations (for 8 weeks) with spinach, strawberry or blueberry extracts in a control diet were also effective in reversing age-related deficits in brain and behavioral function in aged rats¹⁴³. A recent study demonstrates that the tea catechins carry strong anti-aging activity¹⁴⁴

2.2.23.5 Neuro-Protective Effects

Alzheimer's disease is one of the most common diseases in the world and antioxidant properties of polyphenols are already well documented and consumption of polyphenols may provide protection in neurological diseases¹⁴⁵ like Alzheimer's disease¹⁴⁶. Polyphenols from fruits and vegetables can influence and modulate several cellular processes such as signaling, proliferation, apoptosis, redox balance and differentiation¹⁴⁷. Polyphenols, play important role in Alzheimer's disease by its antioxidant and anti-inflammatory properties¹⁴⁸.

2.2.23.6 Polyphenols and osteoporosis

Isoflavones with weak estrogen-like activity have attracted much attention as a possible alternative treatment to prevent osteoporosis¹⁴⁹. Their osteoprotective effects have been evaluated in mice or rats in which an estrogen deficiency has been induced by ovariectomy. Feeding soy proteins with either normal or reduced isoflavone content to ovariectomized rats also suggested that the osteoprotective effects of soy proteins were due to their isoflavones¹⁵⁰.

2.2.24 Risks associated to polyphenol consumption

The acute toxicity of polyphenols have been reported specially diet rich in tannins¹⁵¹. Many research predict that a high consumption of polyphenols could increase the risk of some diseases like cancers^{152, 153} particularly breast cancer^{154, 155}. Flavonoids may also influence the thyroid function and have goitrogenic effects. A reduction of thyroid peroxidase activity was observed in rats fed a diet supplemented with genistein¹⁵⁶⁻¹⁵⁹.

2.3 Introduction to Vitamin C

Vitamin C (ascorbic acid) is a six-carbon lactone. It is synthesized from glucose in the liver of most mammalian species. But humans, non-human primates and guinea pigs cannot synthesized in their body. Because, for the synthesis of vitamin C, enzyme gulonolactone oxidase is necessary which is absent in these species which is essential for the synthesis of the ascorbic acid immediate precursor 2-keto-l-gulonolactone. The DNA encoding for gulonolactone oxidase has undergone substantial mutation, resulting in the absence of a functional enzyme^{160,161}.

2.3.1 Nomenclature and structure

The designation of the compound 2-oxo-L-threo-hexono-1,4-lactone 2,3-ene-diol or

Vitamin C was changed to ascorbic acid or L-ascorbic acid in 1965 by the IUPAC-IUB commission on biochemical nomenclature¹⁶². Furthermore, the names L-xyloascorbic acid, 3-oxo-L-gulofuranolactone (enol form) and L-3-ketothreohexuronic acid lactone are listed in the Merck Index¹⁶³.

The molecule has an almost planer five-member ring. The two chiral centers at positions 4 and 5 determine the four stereoisomers. Besides L-ascorbic acid only erythorbic acid shows a limited level of vitamin C activity. The stereo chemical assignment of ascorbic acid to the L-series was confirmed by the thesis from L-xylose¹⁶⁴. The structures of isomers of ascorbic acid are given below:

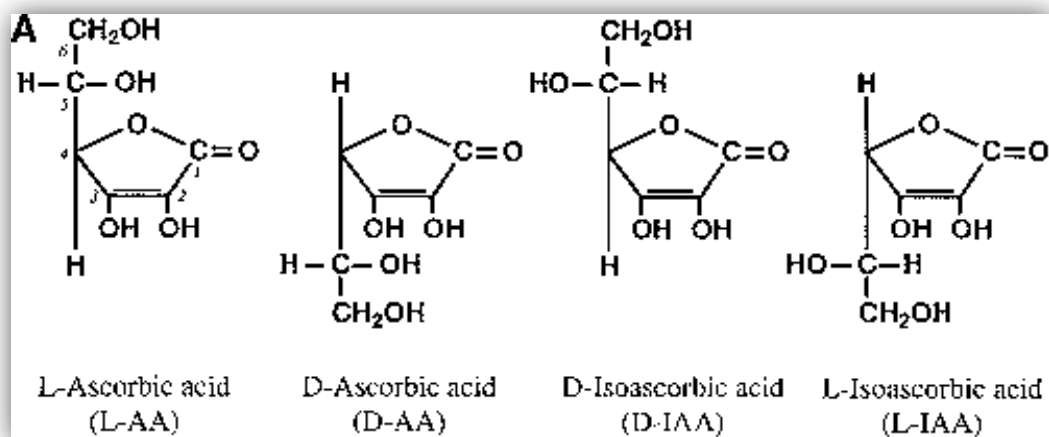

Figure 2.19: Structures of isomers of ascorbic acid

2.3.2 Vitamin C is an electron donor and therefore a reducing agent

All known physiological and biochemical actions of vitamin C are due to its action as an electron donor. Ascorbic acid donates two electrons from a double bond between the second and third carbons of the 6-carbon molecule. Vitamin C is called an antioxidant because, by donating its electrons, it prevents other compounds from being oxidized. However, by the very nature of this reaction, vitamin C itself is oxidized in the process.

Vitamin C donates electrons sequentially. At first, when it loses one electron, a free radical may form which is called semi dehydroascorbic acid or ascorbyl radical. This radical has a half-life of 10^{-5} seconds and is fairly unreactive and comparatively stable. When a reactive and possibly harmful free radical can interact with ascorbate then the reactive free radical is reduced, and a less reactive ascorbyl radical is formed in its place. Reduction of a reactive free radical with formation of a less reactive compound is sometimes called free radical scavenging or quenching. For its chemical properties^{165,166}

Ascorbate is a good free radical scavenger. When Ascorbyl radical loses its second electron, then a compound named dehydroascorbic acid is formed. The stability of Dehydroascorbic acid depends on the following factors, such as:

- temperature and
- pH, and
- time¹⁶⁷.

Dehydroascorbic acid may exist in one of several different structural forms¹⁶⁸. Formation of both ascorbyl radical and dehydroascorbic acid is arbitrated by extensive variety of oxidants in biological systems including molecular oxygen, superoxide, hydroxyl radical, hypochlorous acid, reactive nitrogen species and the trace metals iron and copper.

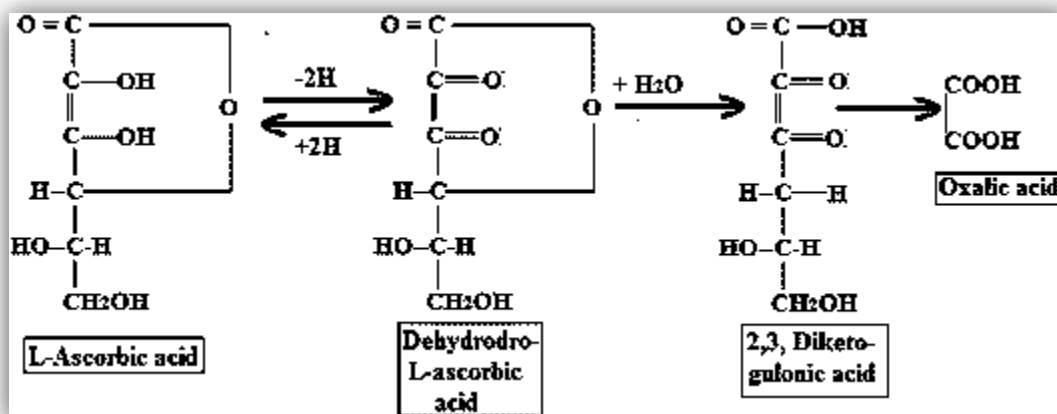

Figure 2.20: Vitamin C, an electron donor and consequently a reducing agent

If dehydroascorbic acid is not reduced back to ascorbic acid, it is hydrolyzed irreversibly to 2, 3 diketogulonic acid. This compound is formed by irreversible rupture of the lactone ring structure that is a part of ascorbic acid, ascorbyl radical, and dehydroascorbic acid. 2,3-diketogulonic acid is further metabolized into xylose, xylonate, lyxonate and oxalate¹⁷⁰. The formation of oxalate has clinical significance because hyperoxaluria (over excretion of oxalate) can result in oxalate kidney stones in some people¹⁶⁹.

2.3.3 Enzymology of Vitamin C

For the action of eight different enzymes Vitamin C acts as an electron donor¹⁷¹ in human. At least for some of the enzymes, ascorbate adds electrons sequentially, with formation of the ascorbyl radical intermediate. These eight enzymes participate in different reactions like,

- Three of eight are involve in collagen hydroxylation¹⁷²⁻¹⁷⁴.
- Two are necessary for synthesis of carnitine^{175,176} (which is essential for the transport of fatty acids into mitochondria for ATP generation).
- One produces nor epinephrine from dopamine^{177, 178},
-)ne adds amide groups to peptide hormones, to increase stability^{179,180}, and
- One modulates tyrosine metabolism^{181,182}.

The enzymes with which ascorbic acid acts function as either monooxygenases or dioxygenases¹⁷¹.

2.3.4 Vitamin C as an Antioxidant in Human Biology

The oxidation of vitamin C by many species that have potential to be involved in human diseases^{183,184}.The relevant species, which receive electrons and are reduced by vitamin C, can be divided into several classes:

- Compounds with unpaired electrons (radicals) such as oxygen related radicals (superoxide, hydroxyl radical, peroxy radicals), sulphur radicals and nitrogen-oxygen radicals.

- Compounds that are reactive but are not radicals, including hypochlorous acid, nitrosamines and other nitrosating compounds, nitrous acid related compounds and ozone.
- Compounds that are formed by reaction with either of the first two classes and then react with vitamin C. An example is formation of the alpha tocopheroxyl radical¹⁸⁵.
- Transition metal-mediated reactions involving iron and copper. For example, some involved in Fenton chemistry¹⁸⁶, some reduced iron may be the ideal form for intestinal absorption^{187,188}.

2.3.5 Detection of Vitamin C Action as an Antioxidant: Biomarkers of Oxidative Reactions

The oxidants just described can react with three general classes of biomolecules. We have categorized them roughly in the order in which they are found, from the outer envelope of the cell, to the interior of the cell: lipid, protein and DNA. If ascorbate is present, it can modify the reactions and their products. For each biomolecule class we will discuss here principles of the oxidant-mediated reactions and reaction products that can be measured and the potential effects of ascorbate. In a subsequent section we will discuss applications of the measurements to *in vitro* and *in vivo* experiments and the limitations of the measurements.

For lipids, membrane lipids and lipids in circulating lipoproteins such as low-density lipoprotein (LDL) can interact with reactive oxygen species resulting in lipid peroxidation. Once lipid peroxides form, they can react with oxygen to form highly reactive peroxy radicals. Continued formation of lipid hydroperoxides can result, a process termed radical propagation. Ascorbate can reduce the initiating reactive oxygen species so that initial or continued lipid peroxidation is inhibited. Markers of lipid peroxidation include measurement of thiobarbituric acid reactive substances (TBARS) and F2-isoprostanes and their metabolites. TBARS are believed to represent production of

malondialdehyde, a peroxidation product of polyunsaturated fatty acids. F2-isoprostanes and their metabolites are relatively stable products of radical mediated peroxidation of arachidonic acid and may be the most reliable markers of lipid peroxidation¹⁸⁹.

A related means to assess lipid oxidation is *ex vivo* oxidation of LDL. The principles supporting use of this measurement are those of the oxidative modification hypothesis^{190,191,192}. This hypothesis, although unproven, is a widely accepted model of atherogenesis in humans and is based on oxidative modification of LDL as an initiating event in atherosclerosis. The major carrier of cholesterol and triglycerides in plasma is low-density lipoprotein (LDL). LDL can infiltrate the intimal layer of arteries and undergo oxidation locally, although the mechanism of oxidation is not fully understood. Oxidized LDL activates adhesion factor expression in endothelial cells. This induces monocytes to adhere to endothelium, where they are activated to differentiate into macrophages, in part via cytokines also induced by oxidized LDL. Macrophages accumulate oxidized LDL and remain in the vascular wall, developing into foam cells and subsequently into fatty streaks, the telltale lesion of atherosclerosis. In theory, the susceptibility of LDL to oxidation *in vivo* can be ascertained by *ex vivo* oxidation, in which LDL isolated from animals or humans is oxidized *in vitro* by added oxidants. If ascorbate reduces either initiating oxidants or oxidized intermediates, LDL oxidation should be decreased.

Proteins also undergo oxidation by several mechanisms^{193,194}. A peptide chain can be cleaved by oxidants, or specific amino acids can be oxidized. The two amino acids most prone to oxidative attack are probably cysteine and methionine. Other amino acids involved include arginine, proline, threonine, tyrosine, histidine, tryptophan, valine and lysine. As occurs in lipids, radical propagation can occur in proteins, with formation of additional reactive species¹⁹⁵. By reducing the radical initiators, ascorbate can prevent protein or amino acid oxidation and radical propagation. Protein oxidation most commonly is measured by detection of modified groups (carbonyl groups) or the oxidized amino acids themselves. Sugars and their oxidized products can also react with lysine

moieties to form advanced glycation end products, although other substrates contribute to these products, such as amino groups on phospholipids. Ascorbate itself is proposed to be a substrate for some advanced glycation end products via oxidation and glyoxal formation, especially in the aging lens¹⁹⁶.

Oxidative processes can affect DNA indirectly through protein oxidation or lipid oxidation or directly by oxidation of DNA^{184,197,198}. Indirect mechanisms leading to DNA damage include protein oxidation, which could alter repair enzymes and DNA polymerases. When reactive oxygen species interact with lipids, resulting lipid peroxidation products might then subsequently react with DNA, inducing mutations¹⁹⁹. Similarly, reactive nitrogen species can also damage proteins needed for oxidant defense or DNA repair or induce lipid peroxidation resulting in further cell damage to lipids, protein or DNA^{200,201}. The most important mechanisms of DNA damage, however, are believed to involve direct attack of oxidants on individual nucleotides in DNA¹⁹⁷. Guanine is the DNA base most susceptible to oxidative attack. When this occurs, there is formation of the nucleotide oxidation product 8 hydroxyguanine (abbreviated 8OHG or 8-oxoG) and its nucleoside derivative 8-hydroxy-2'-deoxyguanosine (abbreviated 8OHdG or 8-oxodG). Both of these compounds can be measured directly or by derivatization¹⁹⁷. DNA can also be damaged by reactive nitrogen species, some of which can be derived from nitrosamines^{200,201}. For example, nitric oxide radicals and related compounds can cause DNA strand breaks and point mutations^{200,201,202}. Ascorbate should be able to diminish DNA damage by reducing radical species directly, decreasing formation of reactive species such as lipid hydroperoxides or preventing radical attack on proteins that repair DNA. Ascorbate as an antioxidant can prevent nitrosamine formation, so subsequent formation of some reactive nitrogen species is prevented. Once nitrosamines give rise to reactive nitrogen species, prevention of mutagenic activity by ascorbate is less effective in prevention of DNA damage²⁰¹.

Thus ascorbate reduces a variety of oxidant species; reactions giving rise to these species might occur in many cell compartments influencing lipids, proteins and DNA, and some

of these reaction products can be quantities, with and without ascorbate. The range of ascorbate concentrations achieved in humans, the influence of the relevant ascorbate concentrations on relevant biomarker measurements as determined by experiments in vitro in animals and in humans, whether biomarker measurements are related to outcome and whether ascorbate influences outcomes predicted by biomarkers.

2.3.6 Dietary Availability

Human cannot synthesize ascorbic acid in the body. So, dietary intake of ascorbic acid is necessary for human. So Human should know the food source of ascorbic acid. Fruits and vegetables are the main source of Vitamin C ²⁰⁴. Kale, mustard greens, pepper (red or green), plantains, potatoes, snow peas, sweet potatoes and tomatoes and tomato juices. Variables that affect vitamin C content of fruits and vegetables are harvesting season, duration of transport to the market place, period of storage and cooking practices.

As a supplement, vitamin C is available in tablet and powder forms in many doses. In addition, vitamin C is included in many multi-vitamin formulations. Vitamin C is commonly combined with other selected vitamins and the resulting complex is collectively sold as an “antioxidant” supplement.

2.3.7 Recommendation for Vitamin C consumption

United States Department of Agriculture and National Cancer Institute guidelines recommend the ingestion of at least five fruits and vegetables daily²⁰⁵⁻²⁰⁸.

According to The third U.S. National Health and Nutrition Examination Survey, (NHANES III Part 1 1988–91) adult males and females should take 84 mg and 73 mg dietary Vitamin C daily, respectively²⁰⁶. In children, 25% of them take below the RDA.²⁰⁹ A survey of Latino children indicated that 85% did not meet the daily recommended intake of fruits and vegetables²¹⁰. These studies did not consider the

supplementary dose of Vitamin C supplements²¹¹. One study reported that half of the USA population does not ingest supplements²¹¹. And a considerable portion of the population still ingests vitamin C at or below the Recommended Dietary Allowance²¹².

Table 2.4. Food Sources of Vitamin C²¹²

Source (Portion Size) Vitamin C,	mg
Fruit	
Cantaloupe (1/4 Medium)	60
Fresh grapefruit (1/2 fruit)	40
Honeydew Melon (1/8 Medium)	40
Kiwi (1 Medium)	75
Mango (1 Cup, sliced)	45
Orange (1 Medium)	70
Papaya (1 Cup, cubes)	85
Strawberries (1 Cup, sliced)	95
Tangerines or tangelos (1 Medium)	25
Watermelon (1 Cup)	15
Juice	
Grapefruit (1/2 Cup)	35
Orange (1/2 Cup)	50
Fortified Juice	
Apple (1/2 Cup)	50
Cranberry juice cocktail (1/2 Cup)	45
Grape (1/2 Cup)	120
Vegetables	
Asparagus, cooked (1/2 Cup)	10
Broccoli, cooked (1/2 Cup)	60
Brussels sprouts, cooked (1/2 Cup)	50
Cabbage	
Red, raw, chopped (1/2 Cup)	20
Red, cooked (1/2 Cup)	25
Raw, chopped (1/2 Cup)	10
Cooked (1/2 Cup)	15
Cauliflower, raw or cooked (1/2 Cup)	25
Kale, cooked (1 cup)	55
Mustard greens, cooked (1 cup)	35
Pepper, red or green	
Raw (1/2 Cup)	65

Cooked (1/2 Cup)	50
Plantains, sliced, cooked (1 Cup)	15
Potato, baked (1 Medium)	25
Snow peas	
Fresh, cooked (1/2 Cup)	40
Frozen, cooked (1/2 Cup)	20
Sweet potato	
Baked (1 Medium)	30
Vacuum Can (1 Cup)	50
Canned, syrup-pack (1 Cup)	20
Tomato	
Raw (1/2 Cup)	15
Canned (1/2 Cup)	35
Juice (6 fluid oz)	35

Table 2.4 is adapted from the article - Levine M, Rumsey SC, Daruwala R, Park JB, Wang Y: Criteria and recommendations for vitamin C intake. JAMA 281:1415–1423, 1999.

2.4 Recent research works on Antioxidant Activities, Vitamin C and Total Phenol Content

In recent years, there has been a great deal of research on the Antioxidant Activities, vitamin C and Total Phenol content of fruits and vegetables in the world. A good number of journal articles were reviewed to gather knowledge on studies conducted on the specific issue. Different samples and different methods were used in different studies. Some of them have been discussed as follows:

A study³³ aimed to determine the Total Phenol Content (TPC) of different varieties of Brinjal and Potato growing in Bangladesh. This study found that different varieties of Brinjal varied from 3.16 ± 0.04 to 7.86 ± 0.33 mg GAE/g of fresh weight (FW). They revealed that BARI Begun-8 is the high yielding varieties of Brinjal and Potato with peel are good sources of polyphenols.

Another study conducted to determine the Antioxidant Capacity (AC) and Total Phenolic Content (TPC) of selected commonly consumed Bangladeshi vegetables and herbs. Ten vegetables and two herbs were analyzed. TPC and Antioxidant capacity (AC) were determined spectrophotometrically according to the Folin-Ciocalteu method and DPPH Free Radical Scavenging Assay respectively. AC varied from 8328.80 ± 29.15 to 0.61 ± 0.19 $\mu\text{mol Trolox Equivalent (TE)/g}$ of FW. Antioxidant capacity of the assayed samples correlated significantly and positively with total phenolic content ($R^2=0.814$, $p<0.01$)³².

In 2012, a study was on hydrophilic antioxidant capacities and total phenol content of seasonal fruits of Bangladesh conducted using DPPH Free Radical Scavenging Assay and Folin-Ciocalteu method. TPC ranged from 0.6 ± 0.01 to 0.01 ± 0 mg Gallic acid equivalent (GAE)/g of fresh weight (FW). Antioxidant capacity varied from 4.882 ± 0 to 0.113 ± 0.03 micromol Trolox Equivalents (TE)/g of FW³⁴.

Recently another study in Bangladesh conducted to determine antioxidant capacity and total phenol contents in hydrophilic extracts of selected Bangladeshi medicinal plants. Folin-Ciocalteu and DPPH radical scavenging assays were employed to determine TPC and AC, respectively. TPC (mean \pm SD), varied from 0.04 ± 0.01 (Amaranthus spinosus) to 6.01 ± 0.04 (Zanthoxylum rhetsa) mg gallic acid equivalent/g Fresh weight. AC (mean \pm SD), from 0.14 ± 0.00 (Alternanthera philoxeroides) to 7.54 ± 0.00 (Zanthoxylum rhetsa) $\mu\text{mol trolox equivalent/g}$ fresh weight³⁵.

The antioxidant activity of the fruits available in the Aizawl market of Mizoram, India was estimated in a study. A total of 20 fruits were evaluated for their antioxidant activity. The highest antioxidant activity was observed in Amla and least in coconut water²¹³.

In order to investigate antioxidant activities in 110 fruits and vegetables, DPPH, FRAP, ABTSTRP assays were used in a study conducted in China. They found Phenolics and flavonoids, rather than vitamin C, contributed to antioxidant potential in most fruits and vegetables²¹⁴.

A review article on the antioxidant effect of certain fruits, published in 2013. This review presents some information about the antioxidant/ and their role in our body and also their presence in a few fruits selected for the study. These fruits namely are pomegranate, guava, papaya and watermelon. The fruits described in this review indicate the importance of antioxidants and their nutritional importance. Researchers are being conducted in this field to know more about these antioxidative fruits and their contribution in preventing early onset of disorders like myocardial infarction, hypoxic ischaemia, coronary heart disease, atherosclerosis, erectile dysfunction in males²¹⁵.

Sixty-six types of commonly consumed vegetables in Singapore were analyzed in a study published in 2009 for their hydrophilic oxygen radical absorbance capacity (H-ORAC), total phenolic content (TPC), ascorbic acid (AA) and various lipophilic antioxidants. They conclude that dark green leafy and brightly-coloured vegetables contain high antioxidants²¹⁶.

Similar type of study applying similar method conducted also in Singapore with thirty-eight types of commonly consumed Singaporean fruits. They found different antioxidant composition and concentration in different fruits. They found that sapodilla (*Manilkara zapota*) had the highest H-ORAC and TPC whilst guava had the highest ascorbic acid per gram fresh weight²¹⁷.

A study conducted in Iran with 14 different varieties of date palm to estimate the antioxidant activity and total phenolic compounds. They found a significant correlation between the total phenolic content and antioxidant activity ($R^2 = 0.791$, $P < 0.001$) of the one variety of date palm, which can indicate that polyphenols are the main antioxidants²¹⁸.

In 1998, a study conducted in Canada, to estimate TPC using the Folin–Ciocalteu method and AA of methanolic extract evaluated according to the β -carotene bleaching method of 28 plant products. They found statistically significant correlation between TPC and AA²¹⁹.

Regularly consumed fruit and vegetables of mixed varieties available on the UK market were analyzed for the composition of the major individual phenolic components, AA and the total phenol content. Vitamin C levels were also determined. They found highest AA in strawberry²²⁰.

3.1 Collection of samples

To estimate the antioxidant activity, Vitamin C and Total Phenol Content, eleven varieties of five fruits and seventeen varieties of five vegetables were selected by BARI. BARI selected their latest varieties for analysis. In the middle of the harvesting seasons, sample was collected in amount of about 0.5 kg/sample item from the research field of BARI grown for standard cultivation practice. All samples were collected as fresh as possible and processed in INFS laboratory for analysis.

3.2 Sample identification & characterization

Collected vegetables were identified and characterized by an expert member (scientific officer) of BARI (Bangladesh Agriculture Research Institute). The taxonomical identification details are given following pages:

Fruits sample

Banana

Taxonomical Classification

Selected varieties of Banana

3.2.1 Sample details

Kingdom:	Plantae
Division:	Magnoliophyta
Class:	Liliopsida
Order:	Zingiberales
Family:	Mucaceae
Genus:	<i>Musa</i>
Species:	<i>M. acuminata</i>
Binomial Name	
<i>Musa acuminata</i>	



**BARI Kola-1
(BARI Sagar Kola)**



BARI Kola-2



**BARI Kola-3
(BARI Champa Kola)**

Fruits sample
Guava

Taxonomical Classification

Selected varieties of Guava

<u>Kingdom:</u>	<u>Plantae</u>
<u>Division:</u>	<u>Magnoliophyta</u>
<u>Class:</u>	<u>Magnoliopsida</u>
<u>Order:</u>	<u>Myrtales</u>
<u>Family:</u>	<u>Myrtaceae</u>
<u>Genus:</u>	<u>Psidium</u>
<u>Species:</u>	<u>P. guajana</u>
<u>Binomial Name</u>	
<u>Psidium guajana</u>	



BARI Kazi Peara



BARI Peara -2

Fruits Sample

Lemon

Taxonomical Classification

Selected variety of Lamon

<u>Kingdom:</u>	<u>Plantae</u>
<u>Division:</u>	<u>Magnoliophyta</u>
<u>Class:</u>	<u>Magnoliopsida</u>
<u>Order:</u>	<u>Sapindales</u>
<u>Family:</u>	<u>Rutaceae</u>
<u>Genus:</u>	<u>Citrus</u>
<u>Species:</u>	<u>C. limon</u>
<u>Binomial Name</u>	
<u>Citrus limon</u>	



BARI Lemon -3

Fruits Sample

Mango

Taxonomical Classification

Selected varieties of Mango

<u>Kingdom:</u>	<u>Plantae</u>
<u>Division:</u>	<u>Magnoliophyta</u>
<u>Class:</u>	<u>Magnoliopsida</u>
<u>Order:</u>	<u>Sapindales</u>
<u>Family:</u>	<u>Anacardiaceae</u>
<u>Genus:</u>	<u>Mangifera</u>
<u>Species:</u>	<u>M. indica</u>
<u>Binomial Name</u>	
<u>Mangifera indica</u>	



BARI Aam -2



BARI Aam -3



BARI Aam-4

Fruits sample

Pineapple

Taxonomical Classification

Selected varieties of Pineapple

<u>Kingdom:</u>	<u>Plantae</u>
<u>Division:</u>	<u>Magnoliophyta</u>
<u>Class:</u>	<u>Liliopsida</u>
<u>Order:</u>	<u>Bromeliales</u>
<u>Family:</u>	<u>Bromeliaceae</u>
<u>Genus:</u>	<u>Ananas</u>
<u>Species:</u>	<u>A comosus</u>
<u>Binomial name</u>	
<u>Anonus comosus</u>	



Justice



Honey Queen

Vegetables Sample

Brinjal

Taxonomical Classification

Selected varieties of Brinjal

<u>Kingdom:</u>	<u>Plantae</u>
<u>Division:</u>	<u>Magnoliophyta</u>
<u>Class:</u>	<u>Magnoliopsida</u>
<u>Order:</u>	<u>Solanales</u>
<u>Family:</u>	<u>Solanaceae</u>
<u>Genus:</u>	<u>Solanum</u>
<u>Species:</u>	<u>S. melongena</u>
<u>Binomial Name</u>	
<u>Solanum melongena</u>	



BARI Begun -1 (Uttara)



BARI Hybrid Begun-3



BARI Begun-4 (kajla)



BARI Begun -5 (Nayantara)

Vegetables Sample
Brinjal

Taxonomical Classification

<u>Kingdom:</u>	<u>Plantae</u>
<u>Division:</u>	<u>Magnoliophyta</u>
<u>Class:</u>	<u>Magnoliopsida</u>
<u>Order:</u>	<u>Solanales</u>
<u>Family:</u>	<u>Solanaceae</u>
<u>Genus:</u>	<u>Solanum</u>
<u>Species:</u>	<u><i>S. melongena</i></u>
<u>Binomial Name</u>	
<u><i>Solanum melongena</i></u>	

Selected Varieties of Brinjal



BARI Begun-6



BARI Begun-8



BARI Begun-10

Vegetables Sample

Pumpkin

Taxonomical Classification

<u>Kingdom:</u>	<u>Plantae</u>
<u>Division:</u>	<u>Magnoliophyta</u>
<u>Class:</u>	<u>Magnoliopsida</u>
<u>Order:</u>	<u>Cucurbitales</u>
<u>Family:</u>	<u>Cucurbitaceae</u>
<u>Genus:</u>	<u>Cucurbita</u>
<u>Species:</u>	<u><i>C. pepo</i></u>
<u>Binomial Name</u>	
<u><i>Cucurbita pepo</i></u>	

Selected varieties of Pumpkin



BARI Mistikumra-1



BARI Mistikumra-2

Vegetables Sample

Radish

Taxonomical Classification

Kingdom:	Plantae
Division:	<i>Magnoliophyta</i>
Class:	<i>Magnoliopsida</i>
Order:	Brassicales
Family:	Brassicaceae
Genus:	<i>Raphanus</i>
Species:	<i>R sativus</i>
Binomial Name	
<i>Raphanus sativus</i>	

Selected Varieties of Radish



BARI Mula-2 (Pinky)



BARI Mula-3 (Druti)

Vegetables Sample

Tomato

Taxonomical Classification

<u>Kingdom:</u>	<u>Plantae</u>
<u>Division:</u>	<u>Magnoliophyta</u>
<u>Class:</u>	<u>Magnoliopsida</u>
<u>Order:</u>	<u>Solanales</u>
<u>Family:</u>	<u>Solanaeae</u>
<u>Genus:</u>	<u>Solanum</u>
<u>Species:</u>	<u>S. lycopersicum</u>
<u>Binomial Name</u>	
<u>Solanum lycopersicum</u>	

Selected Varieties of Tomato



BARI Tomato-14



BARI Tomato-15

3.3 Sample preparation

After collection, samples were weighed, washed under running tap water followed by distilled water and then air dried. After proper dressing refusal of the samples were weighted. Then the edible portion of the samples was divided into 2 parts. One part for extraction of fresh sample for vitamin C estimation and another part for freeze drying for the extraction of TPC and AA.

Edible portion which facilitates freeze drying was cut into small pieces to increase the surface area. Then the samples were weighed again and freeze dried at -180°C until the samples were completely free of moisture. After that, the freeze dried samples were weighed again and grinded finely in a grinder. The ground samples were stored in ziplock bag at -20°C in a refrigerator until analysis.

3.4 Estimation of moisture

Moisture is determined by air oven²²¹. The method is used for the quantitative determination of moisture in food samples.

Moisture content was determined by using the following formula:

$$\% \text{ of moisture} = \frac{\text{Initial weight (g)} - \text{Final weight (g)}}{\text{Weight of fresh sample (g)}} \times 100$$

Where,

Initial weight = Weight of samples before heating.

Final weight = Weight of samples after heating

3.5 Principle of estimation of Vitamin C

The sample was homogenized in 3% metaphosphoric acid. The sample extract, obtained after filtering the homogenate, was chromatographed without preliminary clean-up on an RP C18 column by means of HPLC. Evaluation was carried out by comparing the peak area against an ascorbic acid standard²²².

3.6 Extraction of fresh sample for Vitamin C estimation

3.6.1 Reagents

- Metaphosphoric acid, rods, (60±2% HPO₃, 36±1% NaPO₃)
- Potassium dihydrogen phosphate
- Ortho-phosphoric acid
- L (+) –Ascorbic acid (vitamin C) AR grade chemicals and biochemical purposes.

3.6.2 Preparation of metaphosphoric acid stock solution

3% dissolve 30g of metaphosphoric acid in water, make up to 1000 ml. It was stored c for 7-10 days in frozen codition.

3.6.3 Preparation of 3 M potassium dihydrogen phosphate in 0.35% (v/v) ortho-phosphoric acid

0.408 g KH₂PO₄ was dissolved in 1 L of 0.35% (v/v) ortho-phosphoric acid.

3.6.4 Preparation of ascorbic acid standard solution

100 mg ascorbic acid was dissolved in 3% metaphosphoric acid and made up to 100 ml in a volumetric flask to prepare stock solution (1mg/ml). For working standard, 0.25, 0.5, 1, 2, and 3 ml of stock solution were diluted in 4 different 100 ml volumetric flasks with 3% metaphosphoric acid and mixed properly. The concentrations of ascorbic acid standard solution were 2.5, 5.0, 10, 20 and 30 µg per ml respectively.

3.6.5 Instruments and glass ware

- Usual basic laboratory equipment
- Vortex mixer
- Analytical balance
- Volumetric flask 100 ml
- Glass filter funnel, 15-20 cm diameter
- Filter paper

- HPLC consisting of :
 - Pump e.g. Waters model 510
 - Injector 20 μ l
 - Column 5 μ m Lichrocard Lichrospher 100 RP 18, 125 x 4 mm, Merck U
V detector:248 nm
 - Integrator

3.6.6 Chromatographic conditions

- Stationary phase: 5 μ m Lichrocard Lichrospher 100 RP1 8 Merck
- Mobile phase: 0.3 potassium dihydrogen phosphate in 0.35% (v/v) ortho-phosphoric acid.
- Flow rate: 0.5 ml/min.
- Detection: by means of the retention time for ascorbic acid and / or co-eluted added reference ascorbic acid, at $\lambda = 248$ nm
- Integrator: data module
- Peak evaluation: by peak area

3.7 Procedure

3.7.1 Sample preparation

About 2.5 g of sample is homogenized in 100 ml volumetric flask with a suitable volume of 3% metaphosphoric acid. After shaking for 2 minutes vigorously, the sample extract was made up to the mark with 3% metaphosphoric acid then filter through Whatman # 4 filter paper and further pass through membrane filter 0.45 μ m. The sample was then transferred into a vial and analyzed by HPLC.

3.7.2 Analysis

The sample extract was then transferred into a vial and analyzed by HPLC.

3.8 Calculation, Unit of expression and test report

Standard test values for the ascorbic acid standard concentrations of ascorbic acid per ml was plotted or calculated by the linear regression.

The values of sample in micrograms of ascorbic acid per ml was read off the standard calibration curve or calculated.

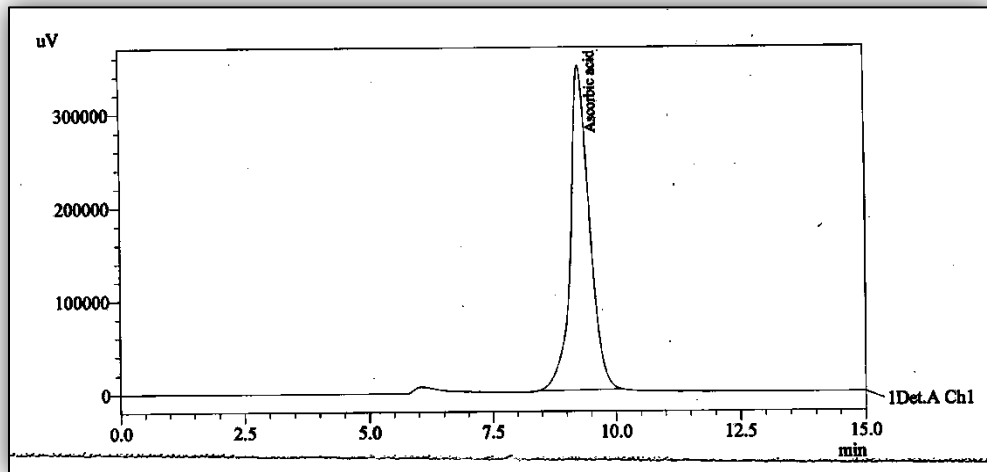

Figure 3.1: Peak area of standard solution

Ascorbic acid content in 100g of the sample material was calculated.

$$\text{Vitamin C (mg/100g)} = \frac{A2 \times C1 \times V}{A1 \times 10 \times W}$$

A1= peak area of standard solution

C1= concentration of standard solution ($\mu\text{g/ml}$)

A2 = peak area of sample

V = final area of sample (ml)

W = weight of sample (g). The result of the determination is in mg/100g sample

3.9 Extraction of freeze dried sample for TPC and AA estimation

3.9.1 Reagents

- n-Hexane (Merck, Germany)
- Dichloromethane (Merck, Germany)
- Acetone (Merck, Germany)
- Acetic acid (Merck, Germany)

3.9.2 Equipment

- Shaker [controlled environmental incubator shaker (New Brunswick Scientific Co; INC; Edition- N.J. U.S.A)]
- Centrifuge machine (Hettich Universal II, Germany)
- Sonicator (ULTRASONICS MEDI-II)
- UV-VIS Spectrophotometer (UV-1800, Shimadzu, Japan)

3.9.3 Solvents for extraction

- Hexane: Dichloromethane (1:1)
- AWA- Acetone: Water: Acetic acid (70: 29.5: 0.5).

3.9.4 Procedure

1 g of ground freeze dried sample was taken. Then 25 ml of Hexane: Dichloromethane (1:1) solvent was added and allowed to shake for overnight in a shaker at the rate of 100 rpm. After completion of shaking the mixture was centrifuged at 1000g for 15 minutes. Then the supernatant was discarded and the precipitate was dried at 60°C until evaporation of the remaining solvents. To the precipitate 25 ml of AWA was added and sonicated for 15 minutes for disrupting the cell matrix of the samples to facilitate the maximum extraction of phenolic compounds from the samples. After sonication the samples were again centrifuged at 1000g for 15 minutes. The supernatant was then

separated and poured in a 25 ml volumetric flask. AWA was added to make the final volume 25 ml. this sample extract then stored in a refrigerator at -20°C until analysis.

3.10 Principle of estimation of TPC

Total phenol was estimated by Folin-Ciocalteu method²²³. Solutions of various types of phenol behave as weak reducing agent and be oxidized to quinone type compounds by many oxidizing agents like Folin-Ciocalteu. Folin-Ciocalteu oxidizes phenolic compounds under alkaline condition and is reduced from its initial golden yellow colour to a deep blue. This reagent is used to measure the phenolic compounds. The absorbance is measured spectrophotometrically at 750 nm wavelength.

3.10.1 Reagents

- Gallic acid (TIC, Japan)
- 2% Sodium Carbonate (w/v) solution
- Folin-Ciocalteu Reagent (FCR) (Merck, Germany)

3.10.2 Preparation of gallic acid standard solution

Stock-I: 1g of gallic acid was dissolved in 10 ml of ethanol and the volume was made up to 100 ml with distilled water in a 100 ml volumetric flask.

Stock-II: An aliquot of 5 ml stock solution was added to 5 ml of AWA to make stock-II.

Working standard solution: 1 ml of stock-II solution was mixed with 9 ml of AWA.

Finally, from the working standard solution, 50 µl, 100 µl, 200µl, 300 µl, 400 µl and 500 µl was taken and the final volume of each of these was made 1 ml with AWA. From each of these 1 ml standard solutions, 100 µl was taken for the preparation of standard curve.

3.10.3 Procedure of Total Phenol estimation

For each sample, 100 µl of sample extracts instead of 100 µl standard solution were taken into 3 vials. Then, 600 µl of distilled water was added to all the vials. To these, 150 µl of 2 times diluted FCR were added and let stand for 5 minutes at room temperature. Then, 750 µl of 2% sodium carbonate solution was added to the mixture and let stand for 15 minutes at room temperature. Finally absorbance was measured at 750 nm in UV-VIS Spectrophotometer.

3.10.4 Calculation

A standard curve was constructed by plotting gallic acid concentration on abscissa and absorbance on ordinate. The concentration of total phenol in sample was calculated from standard curve.

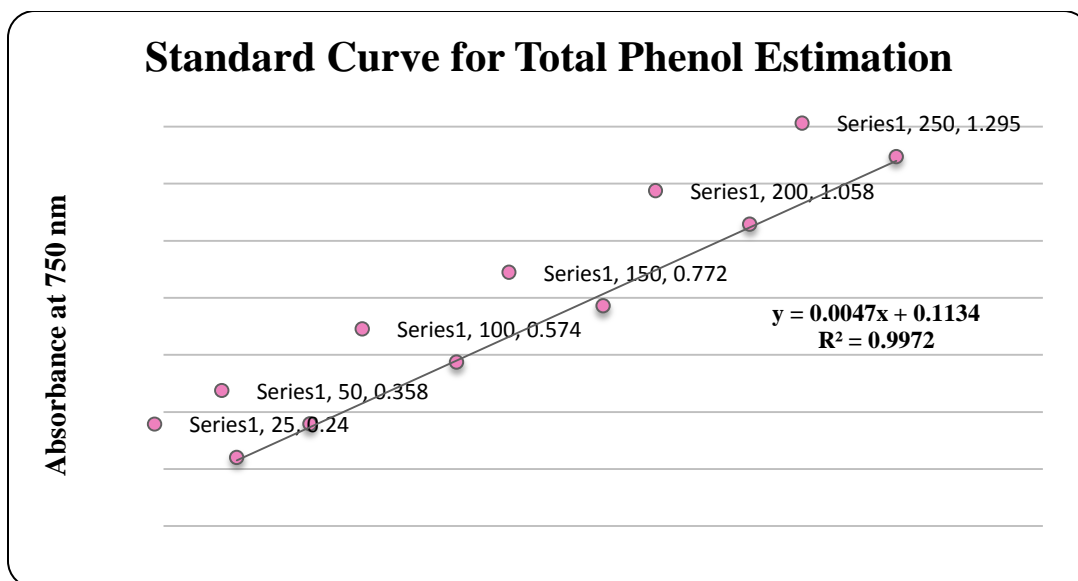

Figure 3.2: Standard curve for Total Phenol estimation

3.11 Estimation of Antioxidant Activity by DPPH (RSA)

Antioxidant activity of AWA extracts of the samples were estimated by DPPH radical scavenging assay method of Brand-Williams et.al²²⁴.

3.11.1 Reagents

- 200 mM MES Buffer (pH 6.0) (Dojindo, Japan)
 - 42.65g MES was dissolved into miliQ water. After adjusting pH to 6.0 by saturated NaOH solution. Up to 1L water was added.
- 400 μ M DPPH (Wako, Japan)
 - 100 ml ethanol was added to 15.76 mg DPPH using brown bottle. Mixed 30 min. DPPH was made every day and used it within 2hrs after making.
- 2.0 mM Trolox stock solution (ALDRICH, Denmark)
 - 12.51 mg of Trolox was dissolved by 50% ethanol and adjusted to 25.0 ml. After preparation solution was subdivided 200 μ l using vial and stocked in -40 C.
- 100 μ M Trolox Working standard solution
- Ethanol (Merck, Germany)

3.11.2 Procedure

3.11.2.1 Trolox dilution for working standard

First 200 μ L of Trolox solution were added with 3.8 ml of 50% acetone.

- 0, 200, 400, 600, 800 μ L of 100 μ M Trolox working standard solution were taken into 5 vials.
- 1000, 800, 600, 400, 200 μ L of 50% acetone were added to the vials respectively.

3.11.2.2 Sample preparation

Sample extracts were mixed with same volume of 30% acetone. If necessary, diluted with 50% acetone.

- 200, 400, 800 μL of samples were put into 3 vials.
- 800, 600, 200 μL of 50% acetone were added to the vials respectively.
- 500 μL of MES buffer was added to all the standards and samples.
- 500 μL of 400 μM DPPH solution was then added to all the vials of standards and samples (one by one at same interval).

3.11.2.3 Blank preparation

- For sample blank, 200, 400 & 800 μL of samples were put into the vials.
- 800, 600, 200 μL of 50% acetone were added to the vials respectively.
- 500 μL of 200 mM MES buffer was added to all Blank vials.
- Instead of DPPH solution, 500 μL of Ethanol was added to all Blanks.

After 20 minutes (room temperature) absorbance was measured at 520 nm in UV-VIS Spectrophotometer

3.11.3 Calculation

A standard curve was constructed by plotting Trolox concentration on abscissa and absorbance on ordinate. The antioxidant capacity of sample was calculated from standard curve.

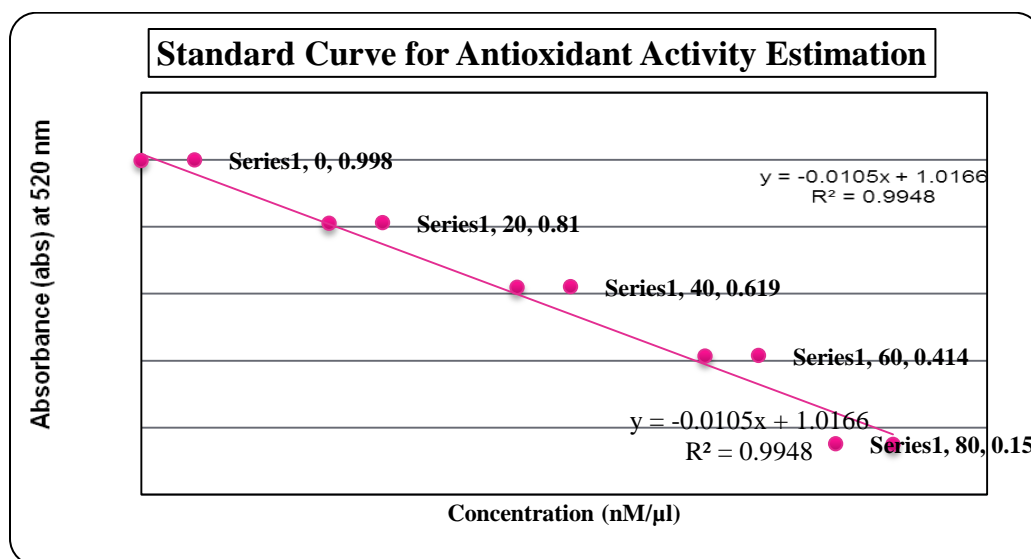

Figure 3.3: Standard curve for antioxidant activity estimation

3.12 Statistical analysis

Mean and standard deviation of the results were calculated. Statistical analysis was done by SPSS 12 and Microsoft Excel 2003.

Numerous epidemiological studies have shown that diet rich in vegetables and fruits significantly reduce the incidence of chronic diseases such as cancer and cardiovascular disease and adequate consumption is a practical approach for chronic diseases prevention. Fruits and vegetables are the abundant source of antioxidants, such as polyphenols, vitamins A, C, and E, carotenoids etc. These compounds are excellent candidates to explain the health benefits of diets rich in fruits and vegetables, although limited information on Polyphenol composition data, bioavailability, interaction with other food components and biological effects are accessible.

4.1 Vitamin C (L-Ascorbic Acid) content

Vitamin C being an electron donor and therefore a reducing agent, acts as an antioxidants i.e. it prevents other compounds from being oxidized

Table 4.1: Vitamin C (L-Ascorbic Acid) content in selected varieties of commonly consumed fruits of Bangladesh (mg L-AA/100 g FW*)

English name	Variety	L- Ascorbic Acid content (mg L-AA/100 g FW*)
Banana	BARI Kola -1 (BARI Sagar Kola)	3.27±0.38
	BARI Kola-2	1.03±0.15
	BARI Kola -3 (BARI Champa Kola)	1.27±0.64
Guava	BARI Kazi Peara	40.30±4.66
	BARI Peara-2	71.57±2.83
Lemon	BARI Lebu-3	37.61±0.00
Mango	BARI Aam -2	2.79±0.21
	BARI Aam -3	22.50±0.32
	BARI Aam -4	36.12±3.61
Pineapple	Justice	5.83±0.40
	Honey Queen	13.53±0.80

*=Fresh weight

Table 4.1 represents Vitamin C (L-Ascorbic Acid) content (mean±SD), expressed as mg of L-AA/100g FW of selected varieties of Banana, Pineapple, Mango, Lemon, & Guava collected

from BARI cultivation field. Amount of L-Ascorbic Acid in analyzed fruits varied from 1.03 ± 0.15 (BARI Kola-2) to 71.57 ± 2.83 (BARI Peara-2) mg/100g FW of the EP. Guava showed highest amount of L-Ascorbic Acid as compared to rest of the four selected fruits. Highest amount of L-Ascorbic Acid was found in BARI Peara-2 (71.57 ± 2.83) and second highest in BARI Kazi Peara (40.30 ± 4.66). Third highest content of L-Ascorbic Acid was found in BARI Lebu-3 (37.61 ± 0.80). Among three selected varieties of Mango from BARI, lowest amount was determined in BARI Mango-2 (2.79 ± 0.21) whereas; BARI Mango-4 (36.12 ± 3.61) had almost 18 times higher amount than BARI Mango-2. Among three selected varieties of Banana, highest L-Ascorbic Acid content was found in BARI Kola-1 (3.27 ± 0.38) and lowest in BARI Kola-2 (1.03 ± 0.15). On the other hand, 13.53 ± 0.80 and 5.83 ± 0.40 mg of L-Ascorbic Acid were found in two varieties of Pineapple: Honey Queen and Justice respectively. Amount of L-Ascorbic Acid in selected varieties of five different fruits are shown as descending order: BARI Peara-2 > BARI Kazi Peara > BARI Lebu-3 > BARI Aam-4 > BARI Aam-3 > Honey Queen > Justice > BARI Kola-1 (BARI Sagar Kola) > BARI Aam-2 > BARI Kola -3 (BARI Champa Kola) > BARI Kola-2.

Table 4.2: Vitamin C (L-Ascorbic Acid) content in selected varieties of commonly consumed vegetables of Bangladesh (mg L-AA/100 g FW*)

English name	Variety	(L- Ascorbic Acid) content (mg L-AA/100 g FW*)
Bottle Gourd	BARI Lau-1	5.17 ± 0.50
	BARI Lau-2	5.77 ± 0.35
	BARI Lau-3	6.37 ± 0.32
	BARI Lau-4	6.13 ± 0.72
Brinjal	BARI Begun-1 (Uttara)	0.93 ± 0.06
	BARI Hybrid Begun-3	0.33 ± 0.05
	BARI Begun-4 (Kajla)	1.07 ± 0.15
	BARI Begun-5(Nayantara)	0.77 ± 0.21
	BARI Begun-6	1.40 ± 0.26
	BARI Begun-8	1.77 ± 0.42
	BARI Begun-10	1.87 ± 0.38
Pumpkin	BARI Mistikumra-1	11.27 ± 0.56
	BARI Mistikumra-2	9.40 ± 0.66
Radish	BARI Mula-2 (Pinky)	14.43 ± 0.21
	BARI Mula-3 (Druti)	13.87 ± 1.02
Tomato	BARI Tomato-14	12.71 ± 2.45
	BARI Tomato-15	12.87 ± 0.32

*=Fresh weight

Table 4.2 reveals that Vitamin C (L-Ascorbic Acid) content (mean±SD) expressed as mg L-AA/100 g of selected varieties of Bottle Gourd, Brinjal, Pumpkin, Radish & Tomato ranged from 0.33±0.05 to 14.43±0.21 mg L-AA/100g of EP. Radish contained highest L-Ascorbic Acid as compared to rest of the four commonly consumed vegetables. Highest L-Ascorbic Acid was found in the variety of BARI Mula-2 (14.43±0.21), then second highest amount in BARI Mula-3 (13.87±1.02). Among the four selected varieties of Bottle gourd, highest L-Ascorbic Acid was found in BARI Lau-3 (6.37±0.32) and lowest in BARI Lau-1 (5.17±0.50). Among seven selected varieties of Brinjal, highest amount of L-Ascorbic Acid was found in BARI Begun-10 (1.87±0.38) and lowest in BARI Hybrid Begun-3 (0.33±0.05). Similarly, 11.27±0.56 and 9.40±0.66 mg of L-Ascorbic acid were found in BARI Mistikumra-1 and BARI Mistikumra-2 respectively. Almost same content was found in two selected varieties of Tomato, 12.87±0.32mg was found in BARI Tomato-15 and 12.71±2.45mg in BARI Tomato-14. Comparatively higher to lower L-Ascorbic Acid of selected varieties of vegetables were as follows: BARI Mula-2 (Pinky) > BARI Mula-3 (Druti) > BARI Tomato-15 > BARI Tomato-14 > BARI Mistikumra-1 > BARI Mistikumra-2 > BARI Lau-3 > BARI Lau-4 > BARI Lau-2 > BARI Lau-1 > BARI Begun-10 > BARI Begun-8 > BARI Begun-6 > BARI Begun-4 (Kajla) > BARI Begun-1 (Uttara) > BARI Begun-5 (Nayantara) > BARI Hybrid Begun-3

4.2 Total Phenol Content (TPC)

Phenolic compounds are a large, diverse group of secondary plant metabolites that are widespread in the plant kingdom and include phenolic acids, flavonoids and tannins¹⁷⁵. The obtained results of total polyphenol analysis of selected samples are given in Table-4.3. Wide range of polyphenol contents were found in the samples of present study.

Table 4.3: Total Phenol Content (TPC) in selected varieties of commonly consumed fruits of Bangladesh ($\mu\text{g GAE}/100\text{g FW}^*$)

English name	Variety	TPC ($\mu\text{gGAE}/\text{g DW}^{**}$)	TPC ($\mu\text{gGAE}/100\text{g FW}^*$)
Banana	BARI Kola -1 (BARI Sagar Kola)	$0.04 \times 10^4 \pm 0.00$	$1.16 \times 10^4 \pm 0.11$
	BARI Kola-2	$0.04 \times 10^4 \pm 0.00$	$1.20 \times 10^4 \pm 0.04$
	BARI Kola -3 (BARI Champa Kola)	$0.03 \times 10^4 \pm 0.00$	$0.92 \times 10^4 \pm 0.13$
Guava	BARI Kazi Peara	$0.77 \times 10^4 \pm 0.00$	$11.31 \times 10^4 \pm 0.11$
	BARI Peara-2	$0.36 \times 10^4 \pm 0.00$	$3.93 \times 10^4 \pm 0.04$
Lemon	BARI Lebu-3	N.D	N.D
Mango	BARI Aam -2	$0.06 \times 10^4 \pm 0.00$	$1.15 \times 10^4 \pm 0.20$
	BARI Aam -3	$0.04 \times 10^4 \pm 0.00$	$0.62 \times 10^4 \pm 0.00$
	BARI Aam -4	$0.07 \times 10^4 \pm 0.00$	$0.83 \times 10^4 \pm 0.03$
Pineapple	Justice	$0.01 \times 10^4 \pm 0.00$	$0.14 \times 10^4 \pm 0.01$
	Honey Queen	$0.05 \times 10^4 \pm 0.00$	$0.86 \times 10^4 \pm 0.04$

** =Dry weight

* =Fresh weight

N.D = Below detection level

Table 4.3 showed the TPC (mean \pm SD) of hydrophilic extracts of Banana, Pineapple, Mango, Lemon, & Guava with selected varieties collected from BARI cultivation system. TPC were varied from $0.14 \times 10^4 \pm 0.01$ (Justice) to $11.31 \times 10^4 \pm 0.11$ $\mu\text{g GAE}/100\text{g FW}$ (BARI Kazi Peara). Among three analyzed varieties of Banana, highest TPC was estimated in BARI Kola-2 ($1.20 \times 10^4 \pm 0.04$) and lowest in BARI Kola-3 ($0.92 \times 10^4 \pm 0.13$). Comparison between two varieties of Pineapple showed that Honey Queen had highest ($0.86 \times 10^4 \pm 0.04$ $\mu\text{g GAE}/100\text{g FW}$) TP content whereas, only $0.14 \times 10^4 \pm 0.01$ $\mu\text{g GAE}/100\text{g FW}$ TPC was found in Justice. Highest TPC was in BARI Aam-2 ($1.15 \times 10^4 \pm 0.20$ $\mu\text{g GAE}/100\text{g FW}$) and lowest in BARI Aam-3 ($0.62 \times 10^4 \pm 0.00$ $\mu\text{g GAE}/100\text{g FW}$) among three selected varieties of Mango. TPC was not detected in BARI Lebu-3. Between two varieties of Guava, around 4 times higher TPC was found in BARI Kazi Peara ($11.31 \times 10^4 \pm 0.11$ $\mu\text{g GAE}/100\text{g FW}$) than BARI Peara-2 ($3.93 \times 10^4 \pm 0.04$ $\mu\text{g GAE}/100\text{g FW}$). TPC of analyzed varieties of fruits are shown as descending order:

BARI Kazi Peara > BARI Peara-2 > BARI Kola-1 (BARI Sagar Kola) > BARI Kola-2 > BARI Aam-2 > BARI Kola-3 (BARI Champa Kola) > Honey Queen > BARI Aam-4 > BARI Aam-3 > Justice.

Table 4.4: Total Phenol Content (TPC) in selected varieties of commonly consumed vegetables of Bangladesh ($\mu\text{g GAE}/100\text{g FW}^*$)

English name	Variety	TPC ($\mu\text{gGAE}/\text{g DW}^{**}$)	TPC ($\mu\text{g GAE}/100\text{g FW}^*$)
Bottle Gourd	BARI Lau-1	$0.06 \times 10^4 \pm 0.00$	$0.33 \times 10^4 \pm 0.01$
	BARI Lau-2	$0.05 \times 10^4 \pm 0.00$	$0.19 \times 10^4 \pm 0.00$
	BARI Lau-3	$0.04 \times 10^4 \pm 0.00$	$0.19 \times 10^4 \pm 0.00$
	BARI Lau-4	$0.05 \times 10^4 \pm 0.00$	$0.22 \times 10^4 \pm 0.00$
Brinjal	BARI Begun-1 (Uttara)	$0.27 \times 10^4 \pm 0.00$	$3.23 \times 10^4 \pm 0.24$
	BARI Hybrid Begun-3	$0.02 \times 10^4 \pm 0.00$	$0.30 \times 10^4 \pm 0.01$
	BARI Begun-4 (Kajla)	$0.18 \times 10^4 \pm 0.00$	$2.10 \times 10^4 \pm 0.19$
	BARI Begun-5 (Nayantara)	$0.06 \times 10^4 \pm 0.00$	$0.36 \times 10^4 \pm 0.03$
	BARI Begun-6	$0.06 \times 10^4 \pm 0.00$	$0.43 \times 10^4 \pm 0.03$
	BARI Begun-8	$0.27 \times 10^4 \pm 0.00$	$2.83 \times 10^4 \pm 0.28$
	BARI Begun-10	$0.12 \times 10^4 \pm 0.00$	$0.99 \times 10^4 \pm 0.01$
Pumpkin	BARI Mistikumra-1	$0.02 \times 10^4 \pm 0.00$	$0.19 \times 10^4 \pm 0.01$
	BARI Mistikumra-2	$0.02 \times 10^4 \pm 0.00$	$0.21 \times 10^4 \pm 0.02$
Radish	BARI Mula-2 (Pinky)	$0.03 \times 10^4 \pm 0.00$	$0.12 \times 10^4 \pm 0.01$
	BARI Mula-3 (Druti)	$0.02 \times 10^4 \pm 0.00$	$0.07 \times 10^4 \pm 0.00$
Tomato	BARI Tomato-14	$0.18 \times 10^4 \pm 0.00$	$0.80 \times 10^4 \pm 0.00$
	BARI Tomato-15	$0.12 \times 10^4 \pm 0.00$	$0.51 \times 10^4 \pm 0.02$

** =Dry weight

*=Fresh weight

TPC (mean \pm SD) expressed as $\mu\text{g GAE}/100\text{g FW}$ of hydrophilic extracts of Bottle Gourd, Brinjal, Pumpkin, Radish & Tomato, ranged from $0.07 \times 10^4 \pm 0.00 \mu\text{g GAE}/100\text{g FW}$ (BARI Mula-3) to $3.23 \times 10^4 \pm 0.24 \times 10^4 \mu\text{g GAE}/100\text{g FW}$ (BARI Begun-1) are presented in Table 4.4. Among the four selected varieties of Bottle Gourd, highest TPC was found in BARI Lau-1 ($0.33 \times 10^4 \pm 0.01 \mu\text{g GAE}/100\text{g FW}$) and lowest in BARI Lau-2 and BARI Lau-3. Equal amount of TPC was found in BARI LAU-2 and BARI LAU-3 ($0.19 \times 10^4 \pm 0.00 \mu\text{g GAE}/100\text{g FW}$). Among the seven varieties of Brinjal, have been analyzed for present study, highest TPC was found in BARI Begun-1 ($3.23 \times 10^4 \pm 0.24 \mu\text{g GAE}/100\text{g FW}$) and lowest in BARI Begun-3 ($0.30 \times 10^4 \pm 0.01 \mu\text{g GAE}/100\text{g FW}$).

Comparison between two selected varieties of Pumpkin showed that $0.19 \times 10^4 \pm 0.01 \mu\text{g}$ GAE/100g FW TPC was found in BARI Mistikumra-1 and $0.21 \times 10^4 \pm 0.02 \mu\text{g}$ GAE/100g FW in BARI Mistikumra-2. Very narrow range of TPC was found between two varieties of Radish. Comparison between two varieties of Tomato showed that higher TPC was found in BARI Tomato-14 ($0.80 \times 10^4 \pm 0.00 \mu\text{g}$ GAE/100g FW) than BARI Tomato-15 ($0.51 \times 10^4 \pm 0.02 \mu\text{g}$ GAE/100g FW). TPC of five commonly consumed vegetables with selected varieties of vegetables are shown as descending order : BARI Begun-1 (Uttara) > BARI Begun-8 > BARI Begun-4 (Kajla) > BARI Begun-10 > BARI Tomato-14 > BARI Tomato-15 > BARI Begun-6 > BARI Begun-5 (Nayantara) > BARI Lau-1 > BARI Hybrid Begun-3 > BARI Mistikumra-1 > BARI Lau-4 > BARI Lau-2 = BARI Lau-3 = BARI Mistikumra-2 > BARI Mula-2 (Pinky) > BARI Mula-3 (Druti).

4.3 Antioxidant Activity (AA) by DPPH Radical Scavenging Assay

DPPH is a stable free radical and accepts an electron or hydrogen radical to become a stable diamagnetic molecule. The reaction of specific compounds (extracts) with DPPH in ethanol solution. In the presence of hydrogen donors, DPPH is reduced and a free radical is formed from scavenger. The reaction of DPPH is monitored by the decrease of the absorbance of its radical at 570 nm, but upon reduction by an antioxidant, the absorption disappears. All the vegetables studied showed appreciable free radical scavenging activities.

Table 4.5: Antioxidant Activity (AA) in selected varieties of commonly consumed fruits of Bangladesh by DPPH Radical scavenging assay ($\mu\text{M TE}/100\text{g FW}^*$)

English name	Variety	DPPH ($\mu\text{M TE}/\text{g DW}^{**}$)	DPPH ($\mu\text{M TE}/100\text{g FW}^*$)
Banana	BARI Kola-1 (BARI Sagar Kola)	2.81 \pm 0	78.00 \pm 8.46
	BARI Kola-2	2.65 \pm 0	65.00 \pm 0.00
	BARI Kola-3 (BARI Champa Kola)	1.75 \pm 0	44.00 \pm 7.73
Guava	BARI Kazi Peara	75.00 \pm 01	109.50 \pm 0.00
	BARI Peara-2	40.00 \pm 0	428.40\pm4.50
Lemon	BARI Lebu-3	0.5 \pm 0	6.41\pm0.00
Mango	BARI Aam-2	7.5 \pm 0	127.85 \pm 1.79
	BARI Aam-3	5.80 \pm 0	82.53 \pm 6.16
	BARI Aam-4	4.76 \pm 0.01	55.66 \pm 6.16
Pineapple	Justice	4.21 \pm 0	52.12 \pm 6.92
	Honey Queen	1.58 \pm 0	26.48 \pm 0.00

** =Dry weight

*=Fresh weight

Antioxidant Activity (AA) by DPPH radical scavenging assay (mean \pm SD) expressed as $\mu\text{M TE}/100\text{g FW}$ of selected varieties of Banana, Pineapple, Mango, Lemon & Guava are presented in Table 4.5. AA of the five commonly consumed fruits were varied from 6.41 \pm 0.00 $\mu\text{M TE}/100\text{g FW}$ ((BARI Lebu-3) to 428.40 \pm 4.50 $\mu\text{M TE}/100\text{g FW}$ (BARI Peara-2). Among the three selected varieties of Banana, highest AA was in BARI Kola-1 (78 \pm 8.46 $\mu\text{M TE}/100\text{g FW}$) and lowest in BARI Kola-3 (44 \pm 7.73 $\mu\text{M TE}/100\text{g FW}$). Comparison between two varieties of Pineapple, Justice showed the highest (52.12 \pm 6.92 $\mu\text{M TE}/100\text{g FW}$) AA than Honey Queen (26.48 \pm 0.00 $\mu\text{M TE}/100\text{g FW}$). Highest AA was found in BARI Aam-2 (127.85 \pm 1.79 $\mu\text{M TE}/100\text{g FW}$) and lowest in BARI Aam-4 (55.66 \pm 6.16 $\mu\text{M TE}/100\text{g FW}$) among three selected varieties of Mango from BARI cultivation system. AA was 6.41 \pm 0.00 $\mu\text{M TE}/100\text{g FW}$ in BARI Lebu-3. Comparison between two varieties of Guava showed that, around 4 times higher AA was found in BARI Peara-2 (428.40 \pm 4.50 $\mu\text{M TE}/100\text{g FW}$) than BARI Kazi Peara (109.50 \pm 0.00 $\mu\text{M TE}/100\text{g FW}$). Comparatively higher to lower AA of selected varieties of fruits were as follows: BARI Peara-2 > BARI Aam-2 > BARI Kazi Peara > BARI

Aam-3 > BARI Kola -1 (BARI Sagar Kola) > BARI Kola-2 > BARI Aam-4 > Justice > BARI Kola-3 (BARI Champa Kola) > Honey Queen > BARI Lebu-3

Table 4.6: Antioxidant Activity (AA) in selected varieties of commonly consumed vegetables of Bangladesh by DPPH Radical scavenging assay ($\mu\text{M TE}/100\text{g FW}^*$)

English name	Variety	DPPH ($\mu\text{M TE}/\text{g DW}^{**}$)	DPPH ($\mu\text{M TE}/100\text{g FW}^*$)
Bottle Gourd	BARI Lau-1	1.90 \pm 0.05	10.00 \pm 4.20
	BARI Lau-2	1.00 \pm 0.01	4.00 \pm 0.00
	BARI Lau-3	0.63 \pm 0.00	3.00 \pm 1.20
	BARI Lau-4	2.38 \pm 0.00	9.00 \pm 0.00
Brinjal	BARI Begun-1 (Uttara)	5.70 \pm 0.00	68.22 \pm 0.00
	BARI Hybrid Begun-3	2.15 \pm 0.00	28.00 \pm 0.00
	BARI Begun-4 (Kajla)	9.52 \pm 0.05	106.00 \pm 0.00
	BARI Begun-5 (Nayantara)	3.50 \pm 0.00	20.33 \pm 2.30
	BARI Begun-6	1.28 \pm 0.00	14.00 \pm 2.92
	BARI Begun-8	10.48 \pm 0.00	107.00 \pm 0.00
	BARI Begun-10	3.01 \pm 0.00	24.78 \pm 2.44
Pumpkin	BARI Mistikumra-1	N.D	N.D
	BARI Mistikumra-2	N.D	N.D
Radish	BARI Mula-2 (Pinky)	3.17 \pm 0.00	12.00 \pm 3.62
	BARI Mula-3 (Druti)	2.86 \pm 0.00	9.18 \pm 1.53
Tomato	BARI Tomato-14	14.28 \pm 0.00	61.29 \pm 0.26
	BARI Tomato-15	4.44 \pm 0.05	19.00 \pm 0.48

** =Dry weight

*=Fresh weight

N.D = Below detection level

Table 4.6 represents that AA (mean \pm SD) expressed as $\mu\text{M TE}/100\text{g FW}$ of selected varieties Bottle Gourd, Brinjal, Pumpkin, Radish and Tomato, ranged from 3.00 \pm 1.20 $\mu\text{M TE}/100\text{g FW}$ (BARI Lau-3) to 107.00 \pm 0.00 $\mu\text{M TE}/100\text{g FW}$ (BARI Begun-8). Among the four selected varieties of Bottle gourd, highest AA was in BARI Lau-1 (10.00 \pm 4.20 $\mu\text{M TE}/100\text{g FW}$) and lowest in BARI Lau-3 (3.00 \pm 1.20 $\mu\text{M TE}/100\text{g FW}$). Among seven selected varieties of Brinjal, highest AA was in BARI Begun-8 (107.00 \pm 0.00 $\mu\text{M TE}/100\text{g FW}$) and lowest in BARI Begun-6 (14.00 \pm 2.92 $\mu\text{M TE}/100\text{g FW}$). AA of two different varieties of Pumpkin was found below detection limit. Comparative AA of two selected varieties of Radish showed that, 12.00 \pm 3.62 $\mu\text{M TE}/100\text{g FW}$ AA was found in BARI Mula-2 and 9.18 \pm 1.53 in BARI Mula-3. Around 3

times higher AA was found in BARI Tomato-14 ($61.29 \pm 0.62 \mu\text{M TE}/100\text{g FW}$) than BARI Tomato-15 ($19.00 \pm 0.48 \mu\text{M TE}/100\text{g FW}$). Comparatively higher to lower AA of selected varieties of five commonly consumed vegetables collected from BARI cultivation system were as follows: BARI Begun-8 > BARI Begun-4 (Kajla) > BARI Begun-1(Uttara) > BARI Tomato-14 > BARI Hybrid Begun-3 > BARI Begun-10 > BARI Begun-5 (Nayantara) > BARI Tomato-15 > BARI Begun-6 > BARI Mula-2 (Pinky) > BARI Lau-1 > BARI Mula -3 (Druti) > BARI Lau-4 > BARI Lau-2 > BARI Lau-3.

4.4. Correlation between Total Phenol Content (TPC) and Antioxidant Activity (AA) by DPPH Radical Scavenging Assay (RSA)

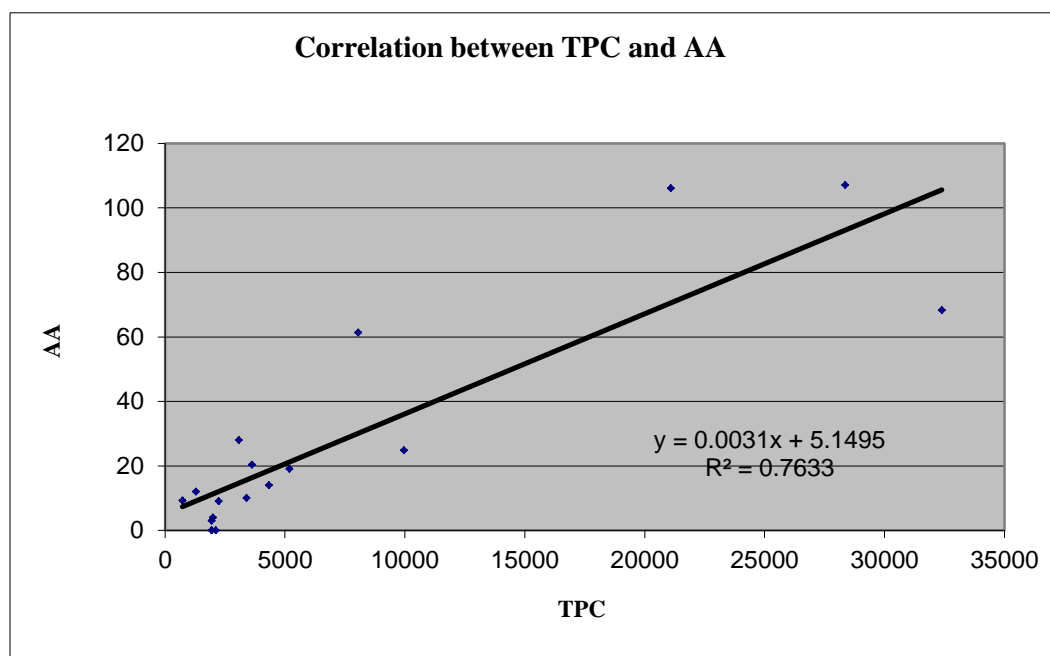

Figure: 4.1: Correlation between TPC and AA among the selected vegetables

A fairly strong positive correlation is found between TPC and AA among the studied vegetables ($R^2 = 0.77$). As indicated by the best fitting trend line in the figure 4.1, certain extend of AA in the studied vegetables might due to other bioactive compounds rather than TPC.

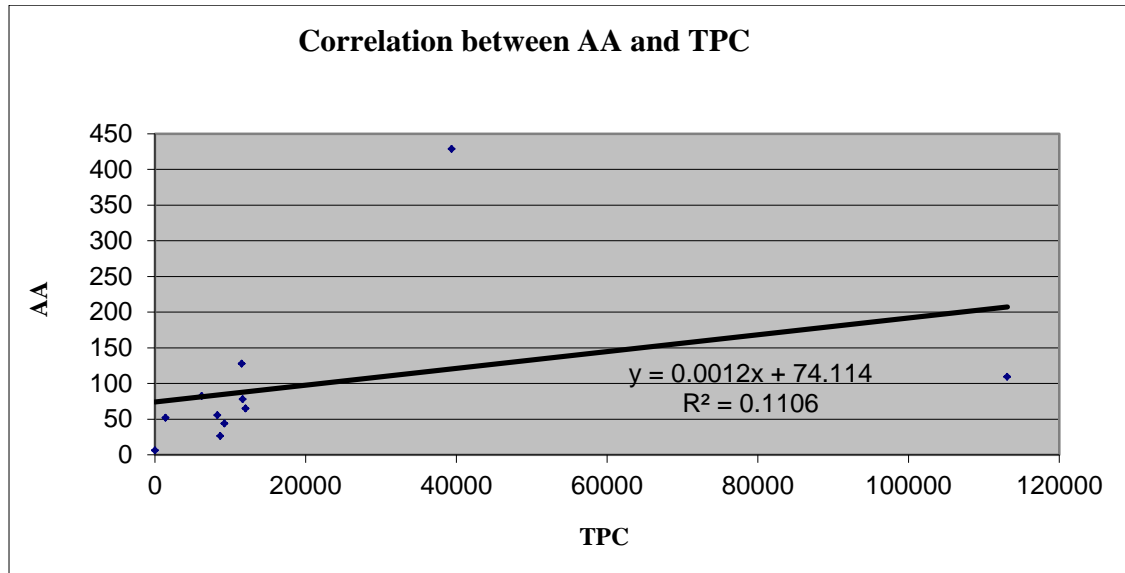

Figure 4.2: Correlation between TPC and AA among the selected fruits

A weak positive correlation is found between TPC and AA among the selected fruits. ($R^2 = 0.11$). As indicated by the best fitting trend line in the figure 4.2, certain extend of AA in the selected fruits was due to other bioactive compounds rather than TPC.

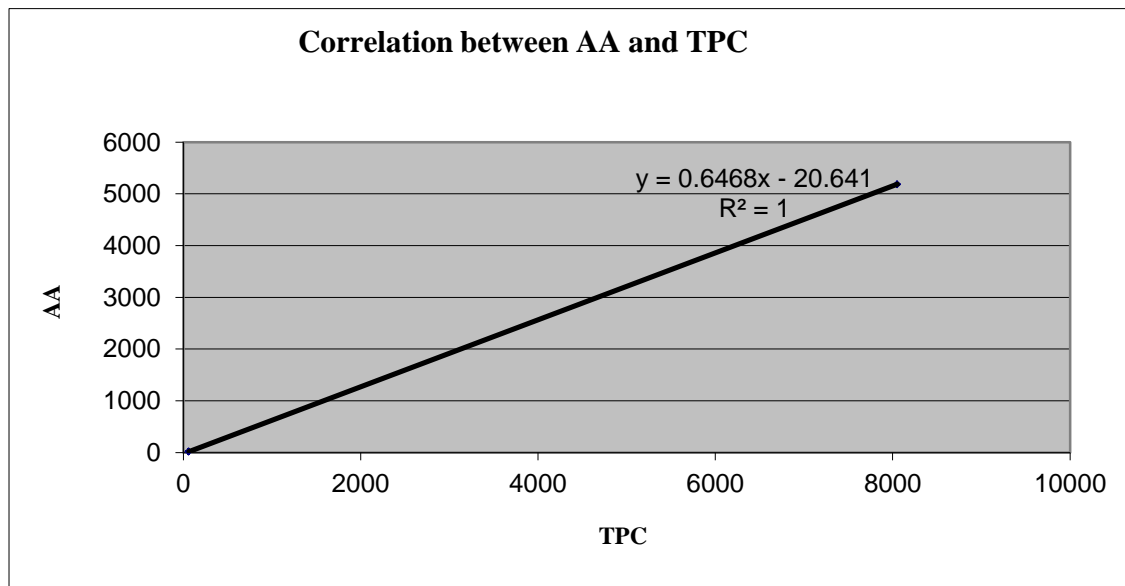

Figure 4.3: Correlation between TPC and AA between two varieties of Tomato

Figure 4.3 represents a perfect positive correlation between TPC and AA between two varieties of Tomato ($R^2 = 1$)

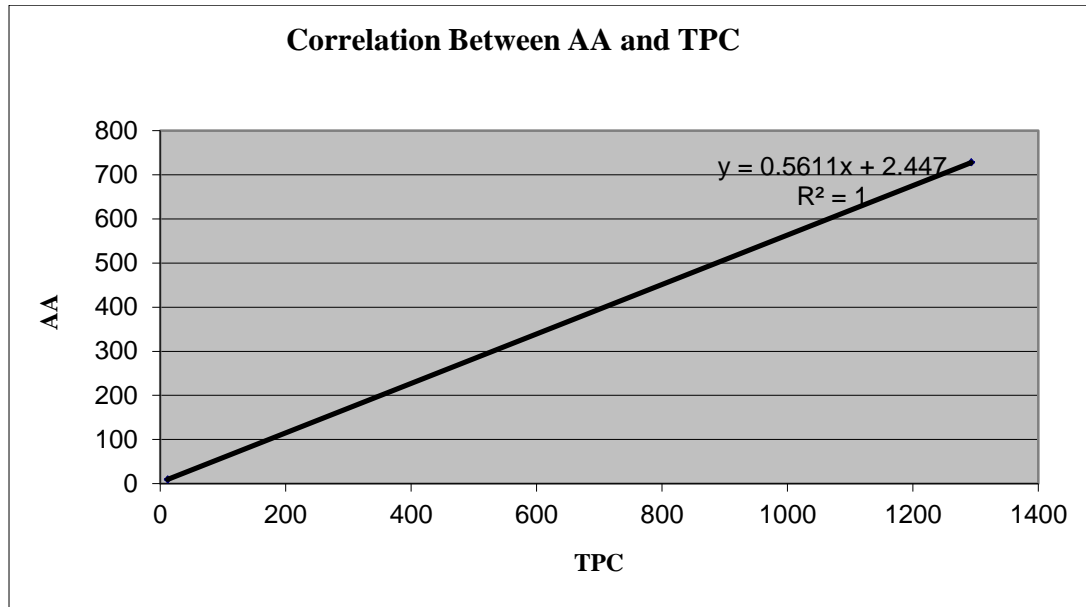

Figure 4.4: Correlation between TPC and AA between two varieties of Radish

Figure 4.4 represents a perfect positive correlation between TPC and AA between two varieties of Radish ($R^2 = 1$)

4.5 Visual relationship between Total Phenol Content (TPC) and Antioxidant Activity (AA)

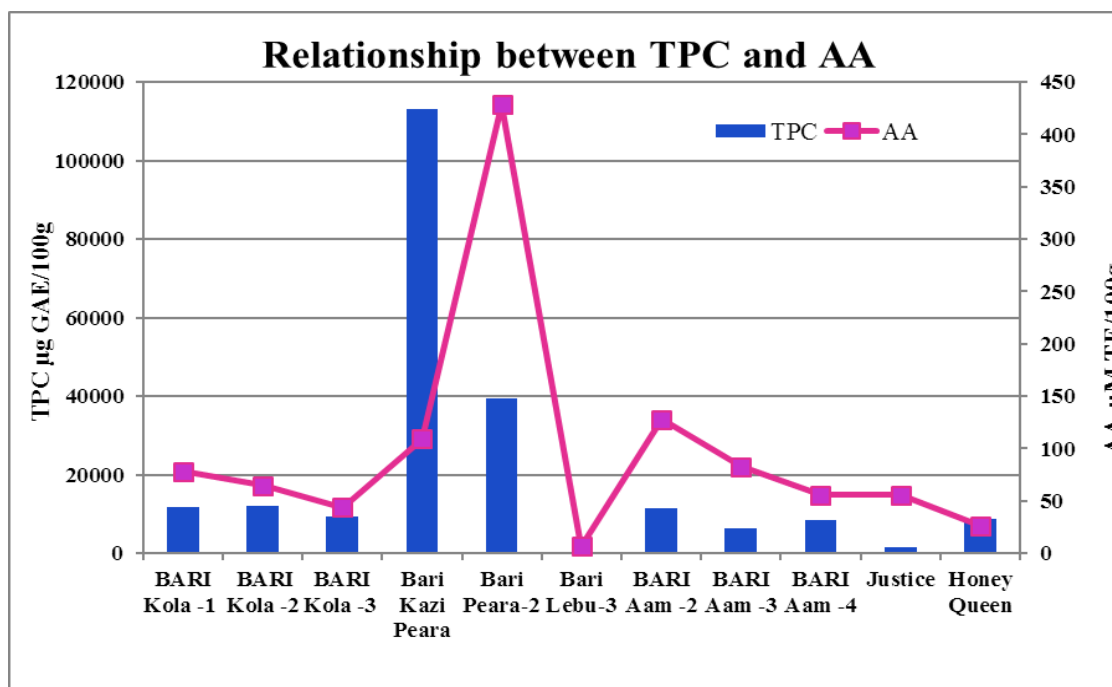

Figure 4.5: Relationship between Total Phenol Content (TPC) and Antioxidant Activity of selected varieties of commonly consumed fruits

Figure 4.5 shows the visual relationship between TPC and AA of selected varieties of Banana, Pineapple, Mango, Lemon and Guava. Blue bar and red line indicate the TPC and AA respectively. This figure revealed that AA of all analyzed samples was not solely corresponding to the TPC. This figure also explained that not all polyphenolic compounds have antioxidant potential. This visual relationship indicates AA of Honey Queen is only well associated with their corresponding phenolic contents.

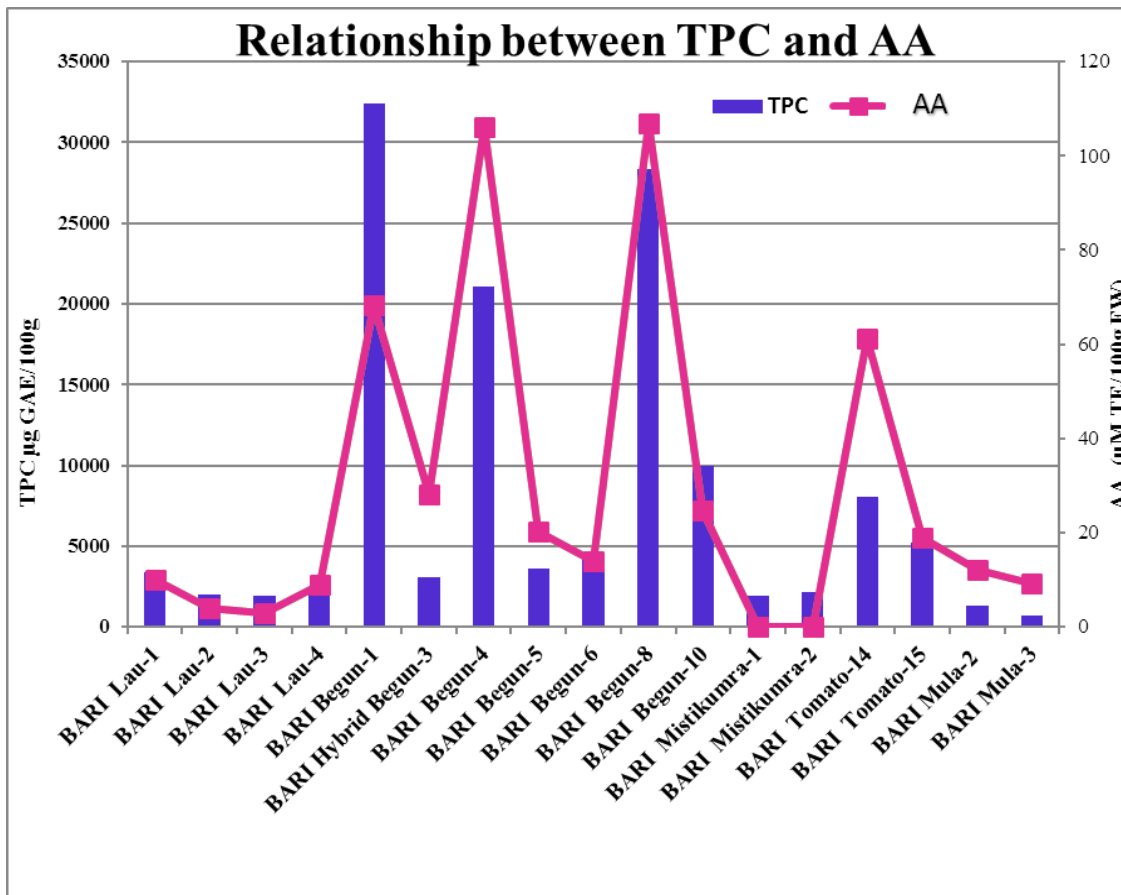

Figure 4.6: Visual relationship between Total Phenol Content (TPC) and Antioxidant Activity of selected varieties of commonly consumed vegetables

Figure 4.6 shows the visual relationship between TPC and AA of selected varieties of Bottle Gourd, Brinjal, Pumpkin, Radish and Tomato. Blue bar and red line indicate the TPC and AA respectively. The Antioxidant activities demonstrated by BARI Lau-1, BARI Lau-4, BARI Begun-6 and BARI Tomato-15 are well matched with their corresponding phenolic contents.

Free radicals are unstable compounds in the body responsible for tissue damage. Antioxidants play a key role in maintaining good health either by counteracting or by preventing these free radicals. Fruits and vegetables, being the potential sources for a range of antioxidants in addition to their culinary properties, have attracted the attention of researchers to evaluate the commonly consumed foods with their varieties as natural potent antioxidants like polyphenols. The mechanisms behind the antioxidant activity of phenolic compounds are thought to involve breakdown of oxidative and nitrosative cascade function at cellular levels. These functions enable them to interact and modulate enzymatic activities and, thereby, regulate signal for cell survival and death²²⁵. As the substances with comparatively higher antioxidant activity in vitro are assumed to show higher antioxidant activity in vivo, several in vitro techniques are commonly employed for rapid screening of the plants extracts based on their antioxidants activity²²⁶.

Fruits and vegetables contain a wide variety of phytochemicals including thousands of bioactive compounds, many of which are implicated with health effects like protective action against heart disease, hypertension, diabetes and some form of cancer. The present study was undertaken to determine Vitamin C and Total Phenol Content (TPC) of hydrophilic extracts and their corresponding Antioxidant Activity (AA) in selected varieties of commonly consumed fruits and vegetables from BARI cultivation field. The findings of present study are a significant addition to the field of food and nutrition research as well as agriculture sector of Bangladesh.

Five fruits and five vegetables have been analyzed for present study with their different varieties, grown in similar cultivation system practiced by BARI. BARI is the largest multi-crop research institute which is conducting research on a wide variety of crops. Besides development of varieties, this institute carries out research on production rate, texture, variation of colour, post-harvest handling and processing, and socio-economic studies related to production, processing, marketing and consumption etc. However, insignificant number of studies was conducted to assess nutrient contents and their

antioxidant activity of newly developed vegetables and fruits by BARI. Therefore, present study was undertaken to assess vitamin C content, one of the most important antioxidant nutrient as well as TPC and their corresponding antioxidant activity of selected recent varieties of fruits and vegetables from BARI.

Vegetables and fruits are important contributors of various vitamins, minerals, and fibers for every day diet of humans. Consequently, fruits are rich in various antioxidant nutrients, including ascorbic acid, beta-carotene and also other bioactive compounds including phenolic compounds. Number of studies demonstrated that the antioxidant bioactive compounds present in certain fruits and vegetables are bioavailable^{225,227}. Therefore, these fruits and vegetables can be considered as an ideal source of natural antioxidants. It is credible to speculate that increasing consumption of these fruits will increase the natural antioxidants in diet, which in the long run, may prevent the chronic diseases as well as aging process by protecting oxidative damage of tissues, protein, DNA etc.

In present study, Vitamin C, Total Phenol Content (TPC) and Antioxidant Activity (AA) of different samples were estimated by HPLC, Folin-Ciocalteu method and DPPH radical scavenging assay respectively. The HPLC is a rapid, sensitive, accurate, and reproducible method of determining vitamin C²²⁸. Folin-Ciocalteu method is simple, rapid and most popular. This method is an electron transfer based assay, and gives reducing capacity which has normally been expressed as phenolic contents. Phenolics are regarded as the molecules with the highest potential to neutralize free radicals. Therefore, their quantification is a common practice in different areas of food research^{32-35,216,217}. In the present study, TPC of the analyzed variety of lemon was below detection level and it showed low AA. However, moderate amount of Vitamin C was found in Lemon. This condition arise might be due to the deactivation of Vitamin C during the sequential extraction of hydrophilic extract. This is the strong evidence that DPPH antioxidant activity contributed by TPC.

Many local sour fruits are rich sources of vitamin C in the Bangladeshi diet whereas vegetables provide comparatively lower amount of the vitamin C. In present study, Vitamin C content (mean±SD) expressed as mg L-Ascorbic Acid (L-AA)/100 g FW of edible portion. The range of Vitamin C content in different varieties of fruits varied from 1.03±0.15 to 71.57±2.83 mg L-AA/100 g FW. Highest Vitamin C was found in Guava (BARI Peara-2) and lowest in Banana (BARI Kola-2). Moderate amount (13.53±0.8083 mg L-AA/100 g FW) of Vitamin C was estimated in Pineapple (Honey Queen). The range of Vitamin C content among all varieties of vegetables was varied from 0.33±0.05 to 14.43±0.21 mg L-AA/100 g FW. Highest vitamin C was observed in Brinjal (BARI Hybrid Begun-3) and lowest in Radish (BARI Mula-2: Pinky). Moderate amount (5.77±0.35 mg L-AA/100 g FW) was found in BARI LAU-2. Negligible amount of vitamin C was found in all 3 varieties of Banana (Table-4.1). A wide range (2.79 to 36.12 mg/100 FW) of Vitamin C content was observed in 3 varieties of Mango. BARI Aam-2 contained extremely low amount of vitamin C (2.79 mg/100 g) and this finding was 'quite exceptional from other studies^{229, 217}. Among the three selected varieties of Mango, BARI Aam-4 contained highest amount of vitamin C (36.12mg/100 g) which is comparable to Fazli variety (34.7 mg/100 g of vitamin C) reported in FCT²²⁹ for Bangladesh. Another popular variety "Langra" contained 103 mg/100 g of vitamin C²²⁹. Comparatively lower amount (17.33 mg/100 g) of Vitamin C was found in Mango in a study conducted in Singapore²¹⁷. Above mentioned study²¹⁷ also reported 70 mg/100 g, 0.22 mg/100 g, and 13.8 mg/100 g of Vitamin C in Guava, Banana and pineapple respectively which are lower than the present findings.

Content of Vitamin C in Bottle Gourd (8.7 mg/100 g), Pumpkin (21.1 mg/100 g) and Radish (17.3 mg/100 g) was higher in FCT for Bangladesh²²⁹ compare with the present findings (Table-4.2). The estimated amount of vitamin C in fruits and vegetables of present study is much lower than the values reported in USDA database²³⁰. One of the possible reasons of this comparatively lower value of Vitamin C is due to the HPLC method employed in this study. This method can estimate only L-ascorbic acid but not

dehydroascorbic acid. Other databases like USDA database reports total ascorbic acid by estimating both of L-ascorbic acid and dehydroascorbic acid.

In the present study, the content of total phenol in analyzed fruits is comparable to the value reported in FCT for Bangladesh²²⁹ however; present findings do not match with Singaporean study²¹⁷. According to FCT for Bangladesh, TPC in Banana, Mango and Pineapple are 1mg GAE/100g, 12 mg GAE/100g and 3 mg GAE/100 g respectively. Total Phenol Content was below detectable limit in BARI Lebu-3 in present study even, a study conducted in Mizoram, India²¹³. A mentionable amount (25.23 mg GAE/100g FW) of TPC is reported in this Indian study. Again, that particular study reported that 115.35 mg GAE/100 g FW, 28.15 mg GAE/100 g FW, 19.01 mg GAE/100 g FW TPC in Guava, Mango and pineapple respectively. These values are higher than the present study findings.

TPC of all varieties of Brinjal was found relatively low in present study, as compared to another study conducted on common vegetables of Singapore²¹⁶. Reported value was 0.82mg GAE/g FW. Variation in TPC of different study, probably due to the use of different solvent system for extraction or varietal differences, cultivation practices used for production and also differences in environmental factors. Previously, a study³³ was conducted on different varieties of Brinjal developed by BARI, reported that 4.24 ± 0.07 , 4.09 ± 0.07 and 7.86 ± 0.33 mg GAE/g FW TPC was in BARI Begun-1, BARI Begun-6 and BARI Begun-8 respectively which were higher than present study. A review article reported that environmental factors have an effect on polyphenolic content includes soil type, sun exposure, rainfall, greenhouse or field, biological culture, hydroponic culture, fruits yield from tree, degree of ripeness etc²³¹. In addition, another review article on bioactive compound reported that Brinjal has anthocyanin, a flavonoid in nature is responsible for violet colour as well as, act as potent antioxidant²³². The colour intensity of violet leads differences in amount of anthocyanin content as well as structural dissimilarity.

AA of analyzed vegetables samples of the present study (presented in table 4.5 and 4.6) was not comparable with the value reported in FCT for Bangladesh²²⁹. Reported values of FCT were 90, 1292, 277, 2435 $\mu\text{M TE}/100\text{g}$ of AA in Brinjal, Radish, Tomato, Bottle Gourd respectively. On the other hand, AA found in Banana (76 $\mu\text{mol TE}/100\text{g}$), Mango (108 $\mu\text{mol TE}/100\text{g}$) and Pineapple (21 $\mu\text{mol TE}/100\text{g}$) in FCT for Bangladesh were almost similar to BARI Sagar Kola (a variety of Banana), BARI Aam-4 (a variety of Mango) and Honey Queen (a variety of Pineapple) of present study. Diverse environmental factors, cultivation system, varietal difference may be the possible reason behind the variation in obtained results.

Among the five fruits and vegetables with different varieties, estimated values of Vitamin C (L-ascorbic acid) and TPC and AA was more in BARI Peara-2 and BARI Kazi Peara, which is comparable with another study reported by Thaipong²³³. This report concluded that both white and pink flesh guavas fruits had high hydrophilic antioxidant activity, vitamin C and Total phenol content. Phenolic compound and vitamin C are the better contributors to the antioxidant activity of guava fruits, compared to the contribution of carotenoids. These antioxidants may be involved in scavenging free radicals to inhibit chain initiation and break chain propagation which is attributed to its high total phenolic compounds. Thus the guava fruit can be harnessed either its protective or preventive roles against diseases caused by oxidative stress.

The AA demonstrated by BARI Lau-1, BARI Lau-4, BARI Begun-6, BARI Tomato-15 and Honey Queen are well associated with their corresponding phenolic contents (Figure 4.5 and 4.6). These figures revealed that AA of all the samples can't not be solely explained by the TPC and not all polyphenolic compounds are antioxidant potential. Antioxidant Activity might be due to other bioactive compounds rather than polyphenols. Furthermore, Mia Isabelle et al²³⁴, explained that vitamin C content of fruits was found to correlate poorly with either total phenolic content or Antioxidant Activity. Other than

vitamin C, there are various other compounds which may contribute more significantly to antioxidant capacities of these fruits.

In present study, recently developed varieties of commonly consumed fruits and vegetables of Bangladesh have been analyzed. From the study findings it might be possible to evaluate varietal difference of Vitamin C, TPC and AA of the analyzed five fruits and vegetables. Obtained result would be helpful for the Agriculture experts for further development of the suitable variety, which will supply adequate amount of micronutrients including Vitamin C as well as other potential sources of antioxidant in every day diet to prevent the chronic diseases and ensure the proper health.

In the present study, AA, TPC and Vitamin C of selected 28 varieties of fruits and vegetables were significantly distributed in four groups using quartiles. 1st to 4th quartiles represent poor, fair, moderate and rich sources of Vitamin C, TPC and AA.

Among all analyzed fruits

Sources of vitamin C:

- Rich sources- BARI Peara-2, BARI Kazi Peara, BARI Lebu-3, BARI Aam-3, BARI Aam-4
- Moderate source- Honey Queen
- Fair sources- BARI Kola-1, BARI Aam-2, Justice
- Poor sources- BARI Kola-2 and BARI Kola-3

Sources of TPC:

- Rich sources- BARI Peara-2, BARI Kazi Peara, BARI Aam-2, BARI Kola-1, BARI Kola-2
- Moderate source- BARI Kola-3
- Fair sources- BARI Aam-3, BARI Aam-4, Honey Queen
- Poor source- Justice

Sources of AA:

- Rich sources- BARI Peara-2, BARI Kazi Peara, BARI Aam-2, BARI Aam-3
- Moderate sources- BARI Kola-1, BARI Kola-2, BARI Kola-3, BARI Aam-4, Justice
- Fair sources- Honey Queen
- Poor source- BARI Lebu-3

Among all analyzed vegetables

Sources of vitamin C:

- Rich sources- BARI Mula-2, BARI Mula-3
- Moderate sources- BARI Lau-3, BARI Lau-4, BARI Tomato-14, BARI Tomato-15, BARI Mistikumra-2, BARI Mistikumra-3
- Fair sources- BARI Lau-1, BARI Lau-2, BARI Begun-8, BARI Begun-10
- Poor sources- BARI Begun-3, BARI Begun-4, BARI Begun-5, BARI Begun-6

Sources of TPC:

- Rich sources- BARI Begun-1, BARI Begun-4, BARI Begun-8
- Moderate source- BARI Begun-10, BARI Tomato-14
- Fair sources- BARI Begun-3, BARI Begun-5, BARI Begun-6, BARI Lau-1, BARI Lau-4
- Poor sources- BARI Lau-2, BARI Lau-3, BARI Mula-2, BARI Mula-3, BARI Mistikumra-2, BARI Mistikumra-3

Sources of AA:

- Rich sources- BARI Begun-4, BARI Begun-8
- Moderate sources- BARI Begun-1, BARI Tomato-14
- Fair sources- BARI Begun-3, BARI Begun-5, BARI Begun-6, BARI Begun-10, BARI Lau-1, BARI Tomato-15, BARI Mula-2
- Poor source- BARI Lau-2, BARI Lau-3, BARI Lau-4, BARI Mula-3.

The findings of the present study indicate some of the selected varieties of fruits and vegetables cultivated by BARI contain considerable amount of Vitamin C and Phenolic compounds that may serve as a potential source of dietary antioxidants in order to tip the balance of body's antioxidant defense system against oxidative stress.

1. In the present study, functional groups could not be estimated due to the time constrains.
2. Other methods of AA were not employed due to unavailability of sophisticated instruments and other logistic supports.

1. Davies, K. J. Oxidative stress, antioxidant defenses and damage removal, repair and replacement systems. *IUBMB life* 2000; 50: 279-289.
2. Fenkel, T. and N. J. Holbrook. Oxidants, oxidative stress and the biology of aging. *Nature* 2000; 408: 240-247.
3. Duh PD, Tu YY, Yen GC. Antioxidant activity of water extract of harnjyur (*Chrysanthemum morifolium* Ramat). *Lebensm. Wiss. Technol* 1999; 32: 269-277.
4. Buyukokuro lu, ME, Gulcin I, Oktay M and Kufrevio O I. In vitro antioxidant properties of dantrolene sodium. *Pharmacol. Res.* 2001; 44: 491-495. *Pharmacological Research*, 2001; Vol. 44 (6): 491-494.
5. Gulcin, Buyukokuro lu ME, Oktay M and Kufrevio lu O. Antioxidant and analgesic activities of turpentine of *Pinus nigra* Arn. Subsp. *pallsiana* (Lamb.) Holmboe. *J. Ethnopharmacol* 2003; 86: 51-58.
6. Hertog MGL, Feskens EJ, Hollman PC, Katan MB, Kronhout D. Dietary antioxidant flavonoids and risk of coronary heart disease. The Zutpan Elderly Study. *Lancet.* 1993; 342: 1007-1011.
7. Jialal I, Grundy SM. Effect of supplementation with alpha tocopherol, ascorbate and beta-carotene on low-density lipoprotein oxidation circulation 1993; 88:2780-2786.
8. P. Denev¹, A. Lojek², M. Ciz², M. Kratchanova. Antioxidant activity and polyphenol content of Bulgarian fruits *Bulgarian Journal of Agricultural Science* 2013; 19 (1): 22-27

9. Institute of Medicine (US). Dietary reference intakes. Proposed definition and plan for review of dietary antioxidants and related compounds. Food and nutrition board. Washington DC: IOM. National Academy Press, Washington, D.C., USA..
10. Bazzano, L A, He J, Ogden L. G, Loria C M, Vupputuri, S, Myers L. Fruit and vegetable intake and risk of cardiovascular disease in US adults: The first national health and nutrition examination survey epidemiologic follow-up study. *American Journal of Clinical Nutrition* 2002; 76: 93–99.
11. Riboli E, Norat T. Epidemiologic evidence of the protective effect of fruit and vegetables on cancer risk. *American Journal of Clinical Nutrition* 2003; 78, 559–569.
12. Liu R. H. Health benefits of fruit and vegetables are from additive and synergistic combinations of phytochemicals. *American Journal of Clinical Nutrition* 2003;78: 517S–520S.
13. The world health report 2002 – Reducing risks, promoting healthy life. Geneva: World Health Organization 2002.
14. Diet, nutrition and the prevention of chronic diseases. In Report of a Joint WHO/FAO Expert Consultation 2003 Geneva: World Health Organization.
15. Lako J, Trenerry V C, Wahlqvist, M, Wattanapenpaiboon N, Sotheeswaran S, Premier R. Phytochemical flavonols, carotenoids and the antioxidant properties of a wide selection of Fijian fruit, vegetables and other readily available foods. *Food Chemistry* 2007; 101(4): 1727–1741.

16. Naczki M, Shahidi F. Phenolics in cereals, fruits and vegetables: Occurrence, extraction and analysis. *Journal of Pharmaceutical and Biomedical Analysis* 2006; 41:1523–1542.
17. Shahidi F, Naczki M. Phenolics in food and nutraceuticals . Boca Raton: CRC Press; 2006.
18. Heber D. What color is your diet? New York: Regan Books; 2001.
19. Young I S, J. Woodside J V. Antioxidants in Health and Disease. *Journal of Clinical Pathology* 2001; 54 (3): 176-186.
20. O. A. Azizova, Role of Free Radical Processes in the Development of Atherosclerosis. *Biologicheskie Membrany* 2002; 19 (6): 451-471.
21. Fu L, Xu B.-T, Xu X.-R, Gan R.-Y, Zhang Y, Xia E.-Q, Li H.-B. Antioxidant Capacities and Total Phenolic Contents of 62 Fruits. *Food Chemistry* 2011; 129 (2): 345-350.
22. Block G, Patterson B, Subar A. Fruit, Vegetables, and Cancer Prevention: A Review of the Epidemiological Evidence. *Nutrition and Cancer* 1992; 18 (1): 1-29.
23. Duthie G G, Duthie S. J, Kyle J A M, Plant Polyphenols in Cancer and Heart Disease: Implications as Nutritional Antioxidants. *Nutrition Research Reviews* 2000; 13 (1): 79-106.
24. Leifert W R, Abeywardena M Y. Cardioprotective Actions of Grape Polyphenols. *Nutrition Research* 2008; 28 (11): 729-737.

25. Leja M, Mareczek A, Ben J. Antioxidant Properties of Two Apple Cultivars during Long-Term Storage. *Food Chemistry* 2003; 80 (3): 303-307.
26. Lotito S B, Frei B. Consumption of Flavonoid Rich Foods and Increased Plasma Antioxidant Capacity in Humans: Cause, Consequence, or Epiphenomenon. *Free Radical Biology and Medicine* 2006; 41 (12): 1727-1746.
27. Rautenbach F, Venter I. Hydrophilic and Lipophilic Antioxidant Capacity of Commonly Consumed South African Fruits, Vegetables, Grains, Legumes, Fats/Oils and Beverages. *Journal of Food Composition and Analysis* 2010; 23 (7). 753-761.
28. Stangeland T, Remberg S F, Lye K A. Total Antioxidant Activity in 35 Ugandan Fruits and Vegetables. *Food Chemistry* 2009; 113 (1) 85-91.
29. Babbar N, Oberoi H S, Uppal D S, Patil R T. Total Phenolic Content and Antioxidant Capacity of Extracts Obtained from Six Important Fruit Residues. *Food Research International* 2011; 44 (1): 391- 396.
30. Govindarajan R., Vijayakumar M, Pushpangadan P. Antioxidant Approach to Disease Management and the Role of Rasayana Herbs of Ayurveda. *Journal of Ethnopharmacolog* 2005; 99 (2):165-178.
31. Bangladesh Demographic and Health Survey-2011
32. Sharmin H, Nazma S, Mohiduzzaman M, Cadi PB. Antioxidant Capacity and Total Phenol Content of Commonly Consumed Selected Vegetables of Bangladesh. *Mal J Nutr.* 2011; 17(3): 377-383.
33. Nazma S, Korshed A A M, Karim K M R, Mohiduzzaman M, Cadi PB, Begum M, Takano-Ishikawa Y. Total Phenol Content of Different Varieties of

Brinjal (*Solanum melongena* L.) and Potato (*Solanum tuberosum* L.) Growing in Bangladesh. *Bangladesh J. Bot.* 2013; 42(1): 175-177.

34. Mamun S, Shaheen N, Basak TA, Mohiduzzaman M, Banu CP, Takano-Ishikawa Y.

Hydrophilic antioxidant capacities and total phenol content of seasonal fruits of Bangladesh. *Mal J Nutr.* 2012; 18:3 355-62.

35. Tukur AbB, Shaheen N, Banu C P, Mohiduzzaman M, Islam S, Begum M, Islam S . Antioxidant capacity and total phenolic contents in hydrophilic extracts of selected Bangladeshi medicinal plants. *Asian Pac J Trop Biomed* 2014; 4(9): 703-708.

36. Akhter KT. Phenolic Content and Antioxidant Activity in the Hydrophilic Extracts of Commonly Consumed Spices in Bangladesh. M.S. Thesis, Institute of Nutrition and Food Science, University of Dhaka. 2014: 60-61.

37. Hazera B. Total Phenol Content (TPC) and Antioxidant Activity(AA) of selected commonly consumed winter vegetables (cauliflower and country bean) of Bangladesh

38. Halliwell B, Gutteridge J M C. *Free Radicals in Biology and Medicine*, 3rd Ed.; Oxford Univ. Press: New York, 2000.

39. Halliwell B. Antioxidants in human health and disease. *Annual Review of Nutrition* 1996; 16: 33-50.

40. <http://www.nutrex-hawaii.com/benefits-of-antioxidants>

41. <http://www.natural-health-information-centre.com/antioxidants.html>

42. <http://health.howstuffworks.com/wellness/food-nutrition/facts/antioxidant1.htm>
43. <http://www.carrotmuseum.co.uk/antiox.html>
44. <http://weightlosscafe4ever.com/tag/high-antioxidant/>
45. <http://www.fitday.com/fitness-articles/nutrition/vitamins-minerals/how-do-antioxidants-benefit-me.html#b>
46. <http://lpi.oregonstate.edu/s-s00/recommend.html>
47. <http://www.betterhealth.vic.gov.au/bhcv2/bhcarticles.nsf/pages/antioxidants>
48. https://nccih.nih.gov/sites/nccam.nih.gov/files/Get_The_Facts_Antioxidants_and_Health_11-01-2013.pdf
49. D'Archivio M, Filesi C, Di Benedetto R, Gargiulo R, Giovannini C, Masella R. polyphenols, dietary sources and bioavailability. *Ann Ist Super Santa* 2007; 43(4): 348-361.
50. Harborne J B, Williams C A. Advances in flavonoid research since 1992. *Phytochemistry* 2000; 55: 481-504.
51. Reinli K, Block G. Phytoestrogen content of foods. A compendium of literature values. *Nutr Cancer*. 1996; 26:123-48.
52. Eisen B, Ungar Y, Shimoni E. Stability of isoflavones in soy milk stored at elevated and ambient temperatures. *J Agric Food Chem*. 2003; 51: 2212-5.

53. Carbini L, Barzanti V, Cipollone M, Fiorentini D, Grossi G, Tolomelli B, Zambonin L, Landi L. Antioxidant and total peroxy radical-trapping ability of olive and seed oils. *J Agric Food Chem.* 2001; 49: 6026-32.
54. Ralph A, Provan G J. *Phytoprotectants, Human nutrition and Dietetics*, Garrow JS. 10th edition. Elsevier Limited. 2000; 417-426.
55. Barker D J P, Shiell A W, Law C M. Growth in utero and blood pressure in next generation. *Journal of hypertension.* 2000; 18:843-846.
56. Manach C, Scalbert A, Morand C, Rémésy C, Jiménez L. Polyphenols: food sources and bioavailability. *Am J Clin Nutr.* 2004; 79: 727– 47.
57. Halliwell B. Dietary polyphenols: Good, bad, or indifferent for your health? *Cardiovasc Res.* 2007; 73:341–347.
58. Nassiri-Asl M, Hosseinzadeh H. Review of the pharmacological effects of *Vitis vinifera* (grape) and its bioactive compounds. *Phytother Res.* 2009; 23:1197–1204.
59. Nijveldt R J, van Nood E, van Hoorn D E C, Boelens P G, van Norren K, van Leeuwen P A M. Flavonoids: A review of probable mechanisms of action and potential applications. *Am J Clin Nutr.* 2001; 74:418–425.
60. Serrano J, Puupponen-Pimia R, Dauer A, Aura AM, Saura-Calixto F. Tannins: Current knowledge of food sources, intake bioavailability and biological effects. *Mol Nutr Food Res.* 2009; 53:1–20.
61. Duthie G G, Duthie S J, Kyle J A M. Plant polyphenols in cancer and heart disease: implications as nutritional antioxidants. *Nutr Res Rev.* 2000; 13:79–106.

62. Andrade R G, Ginani J S, Lopes G K, Dutra F, Alonso A, Hermes-Lima M. Tannic acid inhibits in vitro iron-dependent free radical formation. *Biochimie*. 2006; 88:1287–1296.
63. Lopes G K B, Schulman H M, Hermes-Lima M. Polyphenol tannic acid inhibits hydroxyl radical formation from Fenton reaction by complexing ferrous ions. *Biochim Biophys Acta*. 1999; 1472 (1-2):142–152.
64. Taiz L, Zeiger E. *Plant physiology*, 5th edition, chapter 13, topic13.3.
65. Harborne J B. Plant phenolics. In: Bell EA, Charlwood BV (eds). *Encyclopedia of Plant Physiology*, volume 8. *Secondary Plant Products*, Springer-Verlag, Berlin Heidelberg New York. 1980; 329-395.
66. Crozier A, Burns J, Aziz A A, Stewart A J, Rabiasz H S, Jenkins G I, Edwards C A, Lean M E J. Antioxidant flavonols from fruits, vegetables and beverages: measurements and bioavailability. *Biol Res*. 2000; 33: 79-88.
67. Rice-Evans CA, Miller NJ, Paganga G. Antioxidant properties of phenolic compounds. *Trends in Plant Science*.1997; 2:152-159.
68. Hertog M G L, Feskens E J, Hollman P C, Katan M B, Kronhout D. Dietary antioxidant flavonoids and risk of coronary heart disease. The Zutpan Elderly Study. *Lancet*. 1993; 342: 1007-1011.
69. Birt D F, Bresnick E. Chemoprevention by non-nutrient components of vegetables and fruits. *Cancer and nutrition*, plenum press.1991; 220-260.
70. . Lee K W, Kim Y J, Lee H J, Lee C Y Cocoa has more phenolic phytochemicals and a higher antioxidant capacity than teas and red wine. *J Agric Food Chem*.2003; 51 (25):7292-5.

71. Hara Y. Prophylactic functions of tea polyphenols. In: Ho C-T, Washington D C. 1994; 34-50.
72. Srivastava K C, Mustafa T. Ginger and rheumatic disorders. Medical hypotheses. 1989; 29: 25-28.
73. Wattenburg LW. Inhibition of carcinogenesis by minor dietary constituents. Cancer Research. 1992; 52:2085s-2091s.
74. Amarowicz R, Carle R, Dongowski G. Influence of postharvest processing and storage on the content of phenolic acids and flavonoids in foods. Mol Nutr Food. 2009; 53 (suppl 2):S151–S183.
75. Miglio C, Chiavaro E, Visconti A, Fogliano V, Pellegrini N. Effects of different cooking methods on nutritional and physicochemical characteristics of selected vegetables. J Agric Food Chem. 2008; 56:139–147.
76. Bravo L. Polyphenols: Chemistry, dietary sources, metabolism, and nutritional significance. Nutr Rev. 1998; 56:317–333.
77. Crespy V, Morand C, Besson C, Manach C, Demigne C, Remesy C. Quercetin, but not its glycosides, is absorbed from the rat stomach. J Agric Food Chem. 2002; 50:618–21.
78. Piskula M K, Yamakoshi J, Iwai Y. Daidzein, Daidzein and genistein but not their glucosides are absorbed from the rat stomach. FEBS Lett. 1999; 447: 287–91.
79. Bokkenheuser V D, Shackleton C H L, Winter J. Hydrolysis of dietary flavonoid glycosides by strains of intestinal Bacteroides from humans. Biochem J. 1987; 248: 953–956.

80. Baba S, Furuta T, Fujioka M & Goromaru T. Studies on drug metabolism by use of isotopes.. Urinary metabolites of rutin in rats and role of intestinal microflora in the metabolism of rutin. *J. Pharm. Sci.* 1983; 72: 1155–1158.
81. Adzet T, Camarasa J, Escubedo E, Merlos M. In vitro study of caffeic acid–bovine serum albumin interaction. *Eur J Drug Metab Pharmacokinet.* 1988; 13:11–4.
82. Saija A, Scalese M, Lanza M, Marzullo D, Bonina F, Castelli F. Flavonoids as antioxidant agents: importance of their interaction with biomembranes. *Free Radic Biol Med.*1995; 19:481-6.
83. Castelli F, Uccella N, Trombetta D, Saija A. Differences between coumaric and cinnamic acids in membrane permeation as evidenced by time-dependent calorimetry. *J Agric Food Chem.* 1999; 47:991–5.
84. Nakayama T, Ono K, Hashimoto K. Affinity of antioxidative polyphenols for lipid bilayers evaluated with a liposome system. *Biosci Biotechnol Biochem.* 1998; 62:1005–7.
85. Movileanu L, Neagoe I, Flonta ML. Interaction of the antioxidant flavonoid quercetin with planar lipid bilayers. *Int J Pharm.* 2000; 205: 135–46.
86. Ollila F, Halling K, Vuorela P, Vuorela H, Slotte J P. Characterization of flavonoid-biomembrane interactions. *Arch Biochem Biophys.* 2002; 399:103–8.
87. Vanhet Hof K H, Wiseman S A, Yang C S, Tijburg L B. Plasma and lipoprotein levels of tea catechins following repeated tea consumption. *Proc Soc Exp Biol Med.* 1999; 220:203–9.

88. Gimeno E, Fito M, Lamuela-Raventos R M, et al. Effect of ingestion of virgin olive oil on human low-density lipoprotein composition. *Eur J Clin Nutr.* 2002; 56:114–20.
89. Graefe E U, Wittig J, Mueller S. Pharmacokinetics and bioavailability of quercetin glycosides in humans. *J Clin Pharmacol.* 2001; 41: 492–9.
90. Hollman P C H, Van Trijp J M P, Buysman M NC P. Relative bioavailability of the antioxidant flavonoid quercetin from various foods in man. *FEBS Lett.* 1997; 418:152–6.
91. Manach C, Morand C, Crespy V. Quercetin is recovered in human plasma as conjugated derivatives which retain antioxidant properties. *FEBS Lett.* 1998; 426:331–6.
92. Datla K P, Christidou M, Widmer W W, Rooprai H K, Dexter D T. Tissue distribution and neuroprotective effects of citrus flavonoid tangeretin in a rat model of Parkinson's disease. *Neuroreport.* 2001; 12:3871–5.
93. Abd El Mohsen M M, Kuhnle G, Rechner A R. Uptake and metabolism of epicatechin and its access to the brain after oral ingestion. *Free Radic Biol Med.* 2002; 33:1693–702.
94. Youdim K A, Martin A, Joseph J A. Incorporation of the elderberry anthocyanins by endothelial cells increases protection against oxidative stress. *Free Radic Biol Med.* 2000; 29:51–60.
95. Suganuma M, Okabe S, Oniyama M, Tada Y, Ito H, Fujiki H. Wide distribution of [³H](–)-epigallocatechin gallate, a cancer preventive tea polyphenol, in mouse tissue. *Carcinogenesis.* 1998; 19:1771–6.

96. Chang H C, Churchwell M I, Delclos K B, Newbold R R, Doerge D R. Mass spectrometric determination of Genistein tissue distribution in diet-exposed Sprague-Dawley rats. *J Nutr.* 2000; 130:1963–70.
97. Kim S B, Lee MJ, Hong JI. Plasma and tissue levels of tea catechins in rats and mice during chronic consumption of green tea polyphenols. *Nutr Cancer.* 2000; 37:41–8.
98. Coldham N G, Sauer M J. Pharmacokinetics of [(14) C] Genistein in the rat: gender-related differences, potential mechanisms of biological action, and implications for human health. *Toxicol Appl Pharmacol.* 2000; 164:206–15.
99. Youdim K A, Dobbie M S, Kuhnle G, Proteggente A R, Abbott N J, Rice-Evans C. Interaction between flavonoids and the blood-brain barrier: in vitro studies. *J Neuro chem.* 2003; 85:180–92.
100. Sfakianos J, Coward L, Kirk M, Barnes S. Intestinal uptake and biliary excretion of the isoflavone genistein in rats. *J Nutr.* 1997; 127:1260–8.
101. Kohri T, Nanjo F, Suzuki M. Synthesis of (–)-[4-3H] epigallocatechin gallate and its metabolic fate in rats after intravenous administration. *J Agric Food Chem.* 2001; 49:1042–8.
102. Ishii K, Furuta T, Kasuya Y. Mass spectrometric identification and high-performance liquid chromatographic determination of a flavonoid glycoside naringin in human urine. *J Agric Food Chem.* 2000; 48:56–9.
103. Manach C, Morand C, Gil-Izquierdo A, Bouteloup-Demange C, Remesy C. Bioavailability in humans of the flavanones hesperidin and narirutin after the ingestion of two doses of orange juice. *Eur J Clin Nutr.* 2003; 57:235–42.

104. Erlund I, Meririnne E, Alfthan G, Aro A. Plasma kinetics and urinary excretion of the flavanones naringenin and hesperetin in humans after ingestion of orange juice and grapefruit juice. *J Nutr.* 2001; 131:235–41.
105. Fuhr U, Kummert A L. The fate of naringin in humans: a key to grapefruit juice–drug interactions? *Clin Pharmacol Ther.* 1995; 58:365–73.
106. Lee Y S, Reidenberg M M. A method for measuring naringenin in biological fluids and its disposition from grapefruit juice by man. *Pharmacology.* 1998; 56:314–7.
107. Richelle M, Pridmore-Merten S, Bodenstab S, Enslin M, Offord E A. Hydrolysis of isoflavone glycosides to aglycones by beta-glycosidase does not alter plasma and urine isoflavone pharmacokinetics in postmenopausal women. *J Nutr.* 2002; 132:2587–92.
108. Zhang Y, Hendrich S, Murphy P A. Glucuronides are the main isoflavone metabolites in women. *J Nutr.* 2003; 133:399–404.
109. Xu X, Wang H-J, Murphy P A, Cook L, Hendrich S. Daidzein is a more bioavailable soymilk isoflavone than is genistein in adult women. *J Nutr.* 1994; 124:825–32.
110. Watanabe S, Yamaguchi M, Sobue T. Pharmacokinetics of soybean isoflavones in plasma, urine and feces of men after ingestion of 60 g baked soybean powder (kinako). *J Nutr.* 1998; 128:1710–5.
111. Setchell K D, Faughnan M S, Avades T. Comparing the pharmacokinetics of daidzein and genistein with the use of ¹³C-labeled tracers in premenopausal women. *Am J Clin Nutr.* 2003; 77:411–9.

112. Keith R M, Christy L A. Polyphenols as dietary supplements: A double-edged sword. *Nutrition and Dietary Supplements* 2010; 2:1–12.
113. Halliwell B. Dietary polyphenols: Good, bad, or indifferent for your health? *Cardiovasc Res.* 2007; 73:341–347.
114. Nassiri-Asl M, Hosseinzadeh H. Review of the pharmacological effects of *Vitis vinifera* (grape) and its bioactive compounds. *Phytother Res.* 2009; 23:1197–1204.
115. Nijveldt R J, van Nood E, van Hoorn DEC, Boelens PG, van Norren K, van Leeuwen PAM. Flavonoids: A review of probable mechanisms of action and potential applications. *Am J Clin Nutr.* 2001; 74:418–425.
116. Serrano J, Puupponen-Pimia R, Dauer A, Aura AM, Saura-Calixto F. Tannins: Current knowledge of food sources, intake bioavailability and biological effects. *Mol Nutr Food Res.* 2009; 53:1–20.
117. Duthie G G, Duthie S J, Kyle J A M. Plant polyphenols in cancer and heart disease: implications as nutritional antioxidants. *Nutr Res Rev.* 2000; 13:79–106.
118. Andrade R G, Ginani J S, Lopes G K, Dutra F, Alonso A, Hermes-Lima M. Tannic acid inhibits in vitro iron-dependent free radical formation. *Biochimie.* 2006; 88:1287–1296.
119. Lopes G K, HM, Hermes-Lima M. Polyphenol tannic acid inhibits hydroxyl radical formation from Fenton reaction by complexing ferrous ions. *Biochim Biophys Acta.* 1999; 1472:142–152.

120. Kehrer J P and Smith C V. Free radicals in biology: Sources, reactivities, and roles in the etiology of human diseases. Natural antioxidants, Frei B ed. San Diego, Academic Press. 1994; 25–62.
121. Vitrac X, Moni J P, Vercauteren J, Deffieux G, Mérillon JM. Direct liquid chromatography analysis of resveratrol derivatives and flavanonols in wines with absorbance and fluorescence detection. *Anal Chim Acta*. 2002; 458:103-10.
122. Renaud S, de Lorgeril M. Wine, alcohol, platelets, and the French paradox for coronary heart disease. *Lancet*. 1992; 339:1523-6.
123. Dubick M A, Omaye S T. Evidence for grape, wine and tea polyphenols as modulators of atherosclerosis and ischemic heart disease in humans. *J Nutraceut Functional & Med Foods* 2001; 3:67-93.
124. Nardini M, Natella F, Scaccini C. Role of dietary polyphenols in platelet aggregation. A review of the supplementation studies. *Platelets*. 2007; 18: 224-43.
125. Aviram M, Dornfeld L, Rosenblat M, Volkova N, Kaplan M, Coleman R, Hayek T, Presser D, Fuhrman B. Pomegranate juice consumption reduces oxidative stress, atherogenic modifications to LDL and platelet aggregation: Studies in humans and in atherosclerotic apolipoprotein E-deficient mice. *Am J Clin Nutr*. 2000; 71:1062-76.
126. García-Lafuente A, Guillamón E, Villares A, Rostagno MA, Martínez J A. Flavonoids as anti-inflammatory agents: implications in cancer and cardiovascular disease. *Inflamm Res*. 2009; 58:537-52.

127. Cucciolla V, Borriello A, Oliva A, Galletti P, Zappia V, Della Ragione F. Resveratrol: from basic science to the clinic. *Cell Cycle*. 2007; 6:2495-510.
128. Shakibaei M, Harikumar K B, Aggarwal B B. Resveratrol addiction: to die or not to die. *Mol Nutr Food Res*. 2009; 53:115-28.
129. Yang C S, Landau J M, Huang M T, Newmark H L. Inhibition of carcinogenesis by dietary polyphenolic compounds. *Ann Rev Nutr*. 2001; 21:381-406.
130. Johnson I T, Williamson G, Musk S R R. Anticarcinogenic factors in plant foods: A new class of nutrients? *Nutr Res Rev*. 1994; 7:175-204.
131. Liao S, Umekita Y, Guo J, Kokontis JM, Hiipakka RA. Growth inhibition and regression of human prostate and breast tumors in athymic mice by tea epigallocatechin gallate. *Cancer Lett*. 1995; 96:239-43.
132. Hong J, Bose M, Ju J, Ryu J H, Chen X, Sang S, Lee MJ, Yang CS. Modulation of arachidonic acid metabolism by curcumin and related beta-diketone derivatives: effects on cytosolic phospholipase A2, cyclooxygenases and 5-lipoxygenase. *Carcinogenesis*. 2004; 25:1671-9.
133. Zhang F, Altorki NK, Mestre JR, Subbaramaiah K, Dannenberg AJ. Curcumin inhibits cyclooxygenase-2 transcription in bile acid- and phorbol ester-treated human gastrointestinal epithelial cells. *Carcinogenesis*. 1999; 20:445-51
134. Goel A, Boland CR, Chauhan DP. Specific inhibition of cyclooxygenase-2 (COX-2) expression by dietary curcumin in HT-29 human colon cancer cells. *Cancer Lett*. 2001; 172(2):111-8.

135. Rizvi SI, Zaid MA, Anis R, Mishra N. Protective role of tea catechins against oxidation-induced damage of type 2 diabetic erythrocytes. *Clin Exp Pharmacol Physiol.* 2005; 32:70-5.
136. Rizvi S I, Zaid M A. Insulin like effect of epicatechin on membrane acetylcholinesterase activity in type 2 diabetes mellitus. *Clin Exp Pharmacol Physiol.* 2001; 28:776-8.
137. Matsui T, Ueda T, Oki T, Sugita K, Terahara N, Matsumoto K. Alpha-Glucosidase inhibitory action of natural acylated anthocyanins. 2. alpha-Glucosidase inhibition by isolated acylated anthocyanins. *J Agric Food Chem.* 2001; 49:1952-6.
138. Dembinska-Kiec A, Mykkänen O, Kiec-Wilk B, Mykkänen H. Antioxidant phytochemicals against type 2 diabetes. *Br J Nutr.* 2008; 99:109-17.
139. Rizvi SI, Mishra M. Anti-oxidant effect of quercetin on type 2 diabetic erythrocytes. *J Food Biochem.* 2009; 33:404-15.
140. Harman D. Free radical theory of aging: an update. *Ann N Y Acad Sci.* 2006; 1067:1-12.
141. Cao G, Booth S L, Sadowsky J A, Prior R L. Increases in human plasma antioxidant capacity after consumption of controlled diets high in fruit and vegetables. *Am J Clin Nutr.* 1998; 68:1081-7.
142. Joseph JA, Shukitt-Hale B, Casadesus G. Reversing the deleterious effects of aging on neuronal communication and behavior: beneficial properties of fruit polyphenol.

143. Shukitt-Hale B, Lau FC, Joseph JA. Berry Fruit Supplementation and the Aging Brain. *J Agric Food Chem.* 2008; 56:636-41.
144. Maurya PK, Rizvi SI. Protective role of tea catechins on erythrocytes subjected to oxidative stress during human aging. *Nat Prod Res.* 2008; 1-8.
145. Letenneur L, Proust-Lima C, Le Gouge A, Dartigues J, Barberger-Gateau P. Flavonoid intake and cognitive decline over a 10-year period. *Am J Epidemiol.* 2007; 165:1364-71.
146. Dai Q, Borenstein AR, Wu Y, Jackson JC, Larson EB. Fruit and vegetable juices and Alzheimer's disease: the Kame Project. *Am J Med.* 2006; 119: 751-9.
147. Singh M, Arseneault M, Sanderson T, Murthy V, Ramassamy C. Challenges for research on polyphenols from foods in Alzheimer's disease: Bioavailability, metabolism, and cellular and molecular mechanisms. *J Agric Food Chem.* 2008; 56: 4855-73.
148. Barone E, Calabrese V, Mancuso C. Ferulic acid and its therapeutic potential as a hormetin for age-related diseases. *Biogerontology.* 2009; 10:97-108.
149. Anderson JJB and Garner SC. The effects of phytoestrogens on bone. *Nutrition Research.* 1997; 17:1617–1632.
150. Arjmandi BH, Birnbaum R, Goyal NV, Getlinger MJ, Juma S, Alekel L, Hasler CM, Drum ML, Hollis BW and Kukreja SC. Bone-sparing effect of soy protein in ovarian hormone-deficient rats is related to its isoflavone content. *Am J Clin Nutr.* 1998; 68:1364S–1368S.

151. Clifford MN and Scalbert A. Ellagitannins, occurrence in food, bioavailability and cancer prevention. *J Food Sci Agric.* 2000; 80:1118–1125.

152. Breinholt V and Larsen JC. Detection of weak estrogenic flavonoids using a recombinant yeast strain and a modified MCF7 cell proliferation assay. *Chem. Res. Toxicol.* 1998; 11:622-629.

153. . Tamir S, Eizenberg M, Somjen D, Stern N, Shelach R, Kaye A and Vaya J. Estrogenic and antiproliferative properties of glabridin from licorice in human breast cancer cells. *Cancer Res.*2000;60:5704–5709.

154. Ju YH, Allred CD, Allred KF, Karko KL, Doerge DR and Helferich WG. Physiological concentrations of dietary genistein dose-dependently stimulate growth of estrogen-dependent human breast cancer (MCF-7) tumors implanted in athymic nude mice. *J Nutr.*2001; 131:2957–2962.

155. Petrakis NL, Barnes S, King EB, Lowenstein J, Wiencke J, Lee MM, Miike R, Kirk M and Coward L. Stimulatory influence of soy protein isolate on breast secretion in pre- and postmenopausal women. *Cancer Epidemiol. Biomarkers. Prev.*1996; 5:785–794.

156. Doerge DR and Chang HC. Inactivation of thyroid peroxidase by soy isoflavones, in vitro and in vivo. *J Chromatogr B Analyt Technol Biomed Life Sci.* 2002; 777:269–279.

157. Chang HC and Doerge DR. Dietary genistein inactivates rat thyroid peroxidase in vivo without an apparent hypothyroid effect. *Toxicol Appl Pharmacol.*2000; 168: 244–252.

158. Divi RL and Doerge DR. Inhibition of thyroid peroxidase by dietary flavonoids. *Chemical Research in Toxicology.* 1996; 9:16–23.

159. Fort P, Moses N, Fasano M, Goldberg T and Lifshitz F. Breast and soy-formula feedings in early infancy and the prevalence of autoimmune thyroid disease in children. *J. Am. Coll. Nutr.* 1990; 9:164–167.
160. Nishikimi M, Fukuyama R, Minoshima S, Shimizu N, Yagi K: Cloning and chromosomal mapping of the human nonfunctional gene for L-gulonogamma-lactone oxidase, the enzyme for Lascorbic acid biosynthesis missing in man. *J Biol Chem* 1994; 269:13685–13688.
161. Nishikimi M, Yagi K: Biochemistry and molecular biology of ascorbic acid biosynthesis. *Subcell Biochem* 1996; 25:17–39.
162. IUPAC-IUB Commission on Biochemical nomenclature. *Biochim,Biophys Acto* 1966; 107:1-4.
163. M.Windholz, S Budavari,R F Bluemety and E S Ottebein (EdS.). *The Merck Index .N.J* 1983; 10:120.
164. T Reichstein, A Grussner, R Oppenhauer.*Helv.Chem.Acto* 1933; 16:1019-1033
165. Buettner GR, Moseley PL: EPR spin trapping of free radicals produced by bleomycin and ascorbate. *Free Radic Res Commun* 1993 ;19:S89–S93.
166. Bielski BH, Richter HW, Chan PC: Some properties of the ascorbate free radical. *Ann N Y Acad Sci* 1975; 258:231–237.
167. Washko PW, Wang Y, Levine M: Ascorbic acid recycling in human neutrophils. *J Biol Chem* 1993; 268:15531–15535.

168. Tolbert BM, Ward JB: Dehydroascorbic Acid. In Seib PA, Tolbert BM Ascorbic Acid: Chemistry, Metabolism, and Uses. Washington, DC: American Chemical Society 1982; 101–123.

169. Machlin L J. Handbook of Vitamins. Second edition. 195-226.

170. Lewin S. "Vitamin C: Its Molecular Biology and Medical Potential." London: Academic Press, 1976.

171. Levine M, Rumsey SC, Wang Y, Park JB, Daruwala R. Vitamin C. In Stipanuk MH (ed): "Biochemical and Physiological Aspects of Human Nutrition." Philadelphia: W B Saunders, 2000; 541–567.

172. Prockop DJ, Kivirikko KI: Collagens: molecular biology, diseases, and potentials for therapy. *Annu Rev Biochem* 1995; 64:403–434.

173. Peterkofsky B: Ascorbate requirement for hydroxylation and secretion of procollagen: relationship to inhibition of collagen synthesis in scurvy. *Am J Clin Nutr* 1991. 54:1135S–1140S.

174. Kivirikko KI, Myllyla R: Post-translational processing of procollagens. *Ann N Y Acad Sci* 1985; 460:187–201.

175. Rebouche CJ: Ascorbic acid and carnitine biosynthesis. *Am J Clin Nutr* 1991; 54:1147S–1152S.

176. Dunn WA, Rettura G, Seifter E, England S. Carnitine biosynthesis from gamma-butyrobetaine and from exogenous protein-bound 6-N-trimethyl-L-lysine by the perfused guinea pig liver. Effect of ascorbate deficiency on the in situ activity of gammabutyrobetaine hydroxylase. *J Biol Chem* 1984.; 259:10764–10770.

177. Levine M, Dhariwal KR, Washko P, Welch R, Wang YH, Cantilena CC, Yu R: Ascorbic acid and reaction kinetics in situ: a new approach to vitamin requirements. *J Nutr Sci Vitaminol (Tokyo)* 1992; Spec No:169–172,.
178. Kaufman S: Dopamine-beta-hydroxylase. *J Psychiatr Res* 1974; 11: 303–316,
179. Eipper BA, Milgram SL, Husten EJ, Yun HY, Mains RE: Peptidylglycine alpha-amidating monooxygenase: a multifunctional protein with catalytic, processing, and routing domains. *Protein Sci* 1993; 2:489–497.
180. Eipper BA, Stoffers DA, Mains RE. The biosynthesis of neuropeptides: peptide alpha-amidation. *Annu Rev Neurosci* 1992; 15:57–85,
181. Englard S, Seifter S. The biochemical functions of ascorbic acid. *Annu Rev Nutr* 1986; 6:365–406.
182. Lindblad B, Lindstedt G, Lindstedt S. The mechanism of enzymic formation of homogentisate from p-hydroxyphenylpyruvate. *J Am Chem Soc* 92:7446–7449, 1970.
183. Buettner G R. The pecking order of free radicals and antioxidants: lipid peroxidation, alpha-tocopherol, and ascorbate. *Arch Biochem Biophys* 1993; 300:535–543.
184. Halliwell B. Vitamin C. poison, prophylactic or panacea? *Trends Biochem Sci* 1999; 24:255–259.
185. Neuzil J, Thomas S R, Stocker R. Requirement for, promotion, or inhibition by alpha-tocopherol of radical-induced initiation of plasma lipoprotein lipid peroxidation. *Free Radic Biol Med* 1997; 22: 57–71.

186. Carr A, Frei B. Does vitamin C act as a pro-oxidant under physiological conditions? *Faseb J* 1999; 13:1007–1024.
187. Hallberg L. Iron and vitamins. *Bibl Nutr Dieta* 1995; 52:20–29.
188. Lynch S R. Interaction of iron with other nutrients. *Nutr Rev* 1997; 55:102–110.
189. Morrow J D. The isoprostanes. their quantification as an index of oxidant stress status in vivo. *Drug Metab Rev* 2000; 32:377–385.
190. Steinberg D: Low density lipoprotein oxidation and its pathobiological significance. *J Biol Chem* 1997; 272 : 20963–20966.
191. Heinecke J W. Oxidants and antioxidants in the pathogenesis of atherosclerosis: implications for the oxidized low density lipoprotein hypothesis. *Atherosclerosis* 1998; 141:1–15.
192. Witztum J L, Steinberg D. The oxidative modification hypothesis of atherosclerosis: does it hold for humans? *Trends Cardiovasc Med* 2001; 11:93–102.
193. Berlett BS, Stadtman ER. Protein oxidation in aging, disease, and oxidative stress. *J Biol Chem* 1997; 272:20313–20316.
194. Shacter E. Quantification and significance of protein oxidation in biological samples. *Drug Metab Rev* 32:307–326.
195. Stadtman ER, Berlett B S. Reactive oxygen-mediated protein oxidation in aging and disease. *Drug Metab Rev* 1998; 30:225–243.

196. Baynes J W. The role of AGEs in aging: causation or correlation. *Exp Gerontol* 2001; 36:1527–1537.
197. Halliwell B. Why and how should we measure oxidative DNA damage in nutritional studies? How far have we come? *Am J Clin Nutr*, 2000; 72:1082–1087
198. Halliwell B. Vitamin C and genomic stability. *Mutat Res* 475: 29–35, 2001.
199. Lee SH, Oe T, Blair I A. Vitamin C-induced decomposition of lipid hydroperoxides to endogenous genotoxins. *Science* 2001;292: 2083–2086.
200. Luperchio S, Tamir S, Tannenbaum SR: No-induced oxidative stress and glutathione metabolism in rodent and human cells. *Free Radic Biol Med*1996; 21:513–519.
201. Odin AP. Vitamins as antimutagens: advantages and some possible mechanisms of anti mutagenic action. *Mutat Res* 1997; 386:39–67.
202. Wink DA, Kasprzak KS, Maragos CM, Elespuru RK, Misra M, Dunams TM, Cebula TA, Koch WH, Andrews AW, Allen JS. DNA deaminating ability and genotoxicity of nitric oxide and its progenitors. *Science*1991; 254:1001–1003.
203. Nguyen T, Brunson D, Crespi CL, Penman BW, Wishnok JS, Tannenbaum SR. DNA damage and mutation in human cells exposed to nitric oxide in vitro. *Proc Natl Acad Sci USA* 1992; 89: 3030–3034.
204. Haytowitz D B. Information from USDA's Nutrient Data Bank. *J Nutr*, 1995; 125:1952–1955.

205. Lachance P, Langseth L: The RDA concept: time for a change? *Nutr Rev* 1994; 52:266–270.
206. Life Sciences Research Office. “Third Report on Nutrition Monitoring in the United States.” Washington, DC: US Government Printing Office, 1995.
207. Simon JA, Schreiber GB, Crawford PB, Frederick MM, Sabry Z I Dietary vitamin C and serum lipids in black and white girls. *Epidemiology* 4:537–542,.
208. Basch CE, Zybert P, Shea S. 5-A-DAY: dietary behavior and the fruit and vegetable intake of Latino
209. Simon JA, Schreiber GB, Crawford PB, Frederick MM, Sabry Z I. Dietary vitamin C and serum lipids in black and white girls. *Epidemiology* 1993; 4:537–542,.
210. Basch C E, Zybert P, Shea S. 5-A-DAY: dietary behavior and the fruit and vegetable intake of Latino children. *Am J Public Health* 1994; 84:814–818.
211. Block G, Sinha R, Gridley G: Collection of dietary-supplement data and implications for analysis. *Am J Clin Nutr* 1994; 59:232S–239S.
212. Levine M, Rumsey SC, Daruwala R, Park J B, Wang Y. Criteria and recommendations for vitamin C intake. *JAMA* 1999 ; 281:1415–1423.
213. Ali M A, L, Devi I, Nayan V, Chanu V Kh, Ralte L. Antioxidant activity of fruits available in Aizawl market of Mizoram, India. *International Journal of Biological & Pharmaceutical Research*. 2010; 1(2): 76-81.
214. Changjin Liu^{1,2*}, Yanli Zhao³, Xiaojing Li¹, Jianying Jia¹, Yanya Chen¹, Zetian Hua^{1,2}. Antioxidant Capacities and Main Reducing Substance

Contents in 110 Fruits and Vegetables Eaten in China. *Food and Nutrition Sciences*. 2014; 5 (4)

215. Arshiya S. The Antioxidant effect of certain fruits: - a review. *J. Pharm. Sci. & Res.* Vol.5 (12), 2013, 265- 268

216. Isabelle M, Lee BL, Lim MT, Koh WP, Huang D, Ong CN. Antioxidant activity and profiles of common vegetables in Singapore. *Food Chemistry* 2010; 120 993–1003.

217. Isabelle M, Lee BL, Lim MT, Koh WP, Huang D, Ong CN. Antioxidant activity and profiles of common fruits in Singapore. *Food Chemistry* 123. 2010; 77–84.

218. Ardekan MRS, Khanavi M, Hajimahmoodi M, Jahangiri M, Hadjiakhoondi A. Comparison of Antioxidant Activity and Total Phenol Contents of some Date Seed Varieties from Iran. *Iran J Pharm Res.* 2010 Spring; 9(2): 141–146.

219. Velioglu YS, Mazza G, Gao L and Oomah BD. Antioxidant Activity and Total Phenolics in Selected Fruits, Vegetables, and Grain Products. *J. Agric. Food Chem.* 1998; 46 (10): 4113–4117.

220. Proteggente AR1, Pannala AS, Paganga G, Van Buren L, Wagner E, Wiseman S, Van De Put F, Dacombe C, Rice-Evans CA. The antioxidant activity of regularly consumed fruit and vegetables reflects their phenolic and vitamin C composition. *Biochim Biophys Acta.* 1985 Jul 9; 835(2):298-303.

221. ASEAN Manual of Food Analysis, 2011. Regional Center of ASEAN Network of Food Data System, Institute of Nutrition, Mahidol University, Thailand. p 1-2.

222. ASEAN Manual of Food Analysis, 2011. Regional Center of ASEAN Network of Food Data System, Institute of Nutrition, Mahidol University, Thailand. p 141-143
223. Singleton VL, Rossi JA. Colorimetry of total phenolics with phosphomolybdic-phosphotungstic acid reagents. *Am J Enol Vitic* 1965; 16: 144-158.
224. Brand-Williams W, Cuvelier ME, Berset C. Use of a free radical method to evaluate antioxidant activity. *LWT-Food Sci Technol* 1995; 28: 25-30.
225. Larajinha J. Translation of chemical properties of polyphenols into biological activity with impact on human health. In; Santos-Buelga C, Escribano-Bailon M T, Lattanzio V, editors. *Recent advances in polyphenol research*. 2011; Vol.2. Oxford: Wiley-Blackwell Publishing.
226. Mishra K, Ojha H, Chaudhury NK. Estimation of antiradical properties of antioxidants using DPPH. *Assay: A critical review and results. Food Chem* 2012; 130: 1036-1043
227. Arshiya S. The Antioxidant Effect of Certain Fruits: A Review. *J. Pharm. Sci. & Res* 2013; Vol.5 (12): 265- 268
228. Mitic S S, Kostic D A, Nasković- Đokić D C, Mitic MN. Rapid and Reliable HPLC Method for the Determination of Vitamin C in Pharmaceutical Samples. *Tropical Journal of Pharmaceutical Research* February 2011; 10 (1): 105-111.
229. Shaheen N, Rahim A T M A R, Mohiduzzaman M, Banu C P, Bari M L, Tukun A B, Mannan M A, Bhattacharjee L, Stadlmayr B. Food composition table

for Bangladesh. Institute of Nutrition and Food Science, Centre for Advanced Research in Science, University of Dhaka June 2013.

230. Absorbance Capacity (ORAC) of Selected Foods, Release 2. USDA Database for the Oxygen Radical. Nutrient Data Laboratory Beltsville Human Nutrition Research Center (BHNRC), Agricultural Research Service (ARS), U.S. Department of Agriculture (USDA), May 2010.

231. Sang S, Yang CS, Ho CT. Peroxidase-mediated oxidation of catechins, *Phytochemistry Reviews*. 2004; 3:229-241.

232. Pennington JAT. Study review: Food composition databases for bioactive food components. *J. Food Comp. and Anal* 2002; 15: 419-434

233. Thaipong K, Boonprakob U, Crosby K, Cisneros-Zevallos L, Byrne D. Comparison of ABTS, DPPH, FRAP, and ORAC assays for estimating antioxidant activity from guava fruit extracts. *J. Food Compos Anal*. 19: 669-675.

234. Isabelle M, Lee B. L, Ong C. N, Liu X, Huang D. Peroxyl radical scavenging capacity, polyphenolics, and lipophilic antioxidant profiles of mulberry fruits cultivated in Southern China. *Journal of Agricultural and Food Chemistry* 2008; 56(20): 9410–9416.

